

इंटरनेट

मानक

Disclosure to Promote the Right To Information

Whereas the Parliament of India has set out to provide a practical regime of right to information for citizens to secure access to information under the control of public authorities, in order to promote transparency and accountability in the working of every public authority, and whereas the attached publication of the Bureau of Indian Standards is of particular interest to the public, particularly disadvantaged communities and those engaged in the pursuit of education and knowledge, the attached public safety standard is made available to promote the timely dissemination of this information in an accurate manner to the public.

“जानने का अधिकार, जीने का अधिकार”

Mazdoor Kisan Shakti Sangathan

“The Right to Information, The Right to Live”

“पुराने को छोड़ नये के तरफ”

Jawaharlal Nehru

“Step Out From the Old to the New”

IS 4326 (1993): Code of practice for earthquake resistant design and construction of buildings [CED 39: Earthquake Engineering]



“ज्ञान से एक नये भारत का निर्माण”

Satyanarayan Gangaram Pitroda

“Invent a New India Using Knowledge”



“ज्ञान एक ऐसा खजाना है जो कभी चुराया नहीं जा सकता है”

Bhartrhari—Nitiśatakam

“Knowledge is such a treasure which cannot be stolen”

BLANK PAGE



IS 4326 : 1993
(Reaffirmed 2003)
Edition 3.3
(2005-01)

भारतीय मानक
भवनों की भूकम्प प्रतिरोधी डिजाइन और संरचना — रीति संहिता
(दूसरा पुनरीक्षण)

Indian Standard

**EARTHQUAKE RESISTANT DESIGN AND
CONSTRUCTION OF BUILDINGS —
CODE OF PRACTICE**

(Second Revision)

(Incorporating Amendment Nos. 1, 2 & 3)

UDC 699.841 (026)

© BIS 2005

BUREAU OF INDIAN STANDARDS
MANAK BHAVAN, 9 BAHADUR SHAH ZAFAR MARG
NEW DELHI 110002

Price Group 11

FOREWORD

This Indian Standard was adopted by the Bureau of Indian Standards, after the draft finalized by the Earthquake Engineering Sectional Committee had been approved by the Civil Engineering Division Council.

Himalayan-Naga Lushai region, Indo-Gangetic Plain, Western India and Kutch and Kathiawar regions are geologically unstable parts of the country and some devastating earthquakes of the world have occurred there. A major part of the peninsular India, has also been visited by moderate earthquakes, but these were relatively few in number and had considerably lesser intensity. It has been a long felt need to rationalize the earthquake resistant design and construction of structures taking into account seismic data from studies of these Indian earthquakes, particularly in view of the heavy construction programme at present all over the country. It is to serve this purpose that IS 1893 : 1984 'Criteria for earthquake resistant design of structures' was prepared. It covered the seismic design considerations for various structures. As an adjunct to IS 1893, IS 4326 'Code of practice for earthquake resistant design and construction of buildings' was prepared in 1967 and subsequently revised in 1976 to be in line with IS 1893 : 1975. Since 1984 revision of IS 1893 was minor, it did not require a revision of IS 4326. An expansion of IS 4326 was in fact thought of immediately after the Bihar earthquake of August 1988 when greater attention was needed on low-strength brickwork and stone masonry as well as earthen buildings; also repair, restoration and strengthening of earthquake-damaged buildings posed a serious issue. After intense deliberations, the subcommittee CED 39 : 1 decided to issue separate standards to cover these topics. It was further decided to cover detailing of reinforced concrete for achieving ductility in a separate standard to be used with IS 456 : 1978 'Code of practice for plain and reinforced concrete (*third revision*)'. The present revision is based on these considerations.

Recommendations regarding restrictions on openings, provision of steel in various horizontal bands and vertical steel at corners and junctions in walls and at jambs of openings are based on a range of calculations made using design seismic coefficient and the ductility of steel reinforcement. Many of the provisions have also been verified experimentally on models by shake table tests.

The following are the major changes besides minor amendments affected in this revision of the standard:

- a) Low strength brickwork and stone masonry are removed and developed into a separate standard;
- b) Clauses on ductility details have been removed and developed into a separate standard;
- c) Building categories have been introduced based on basic seismic coefficient, soil-foundation factor and importance factor as per IS 1893 : 1984; and
- d) Size and position of openings in bearing walls has been specified in greater detail.

In this standard, it is intended to cover the specified features of design and construction for earthquake resistance of buildings of conventional types. In case of other buildings, detailed analysis of earthquake forces will be necessary. Recommendations regarding restrictions on openings, provision of steel in various horizontal bands and vertical steel at corners and junctions in walls and at jambs of openings are based on a range of calculations made using steel design seismic coefficient and the ductility of steel reinforcement. Many of the provisions have also been verified experimentally on models by shake table tests.

The Sectional Committee responsible for the preparation of this standard has taken into consideration the views of all who are interested in this field and has related the standard to the prevailing practices in the country. Due weightage has also been given to the need for international co-ordination among the standards and practices prevailing in different countries of the world.

This edition 3.3 incorporates Amendment No. 1 (December 1995), Amendment No. 2 (April 2002) and Amendment No. 3 (January 2005). Side bar indicates modification of the text as the result of incorporation of the amendments.

For the purpose of deciding whether a particular requirement of this standard is complied with, the final value, observed or calculated, expressing the result of a test or analysis, shall be rounded off in accordance with IS 2 : 1960 'Rules for rounding off numerical values (*revised*)'. The number of significant places retained in the rounded off value should be the same as that of the specified value in this standard.

Indian Standard

EARTHQUAKE RESISTANT DESIGN AND CONSTRUCTION OF BUILDINGS — CODE OF PRACTICE

(*Second Revision*)

1 SCOPE

1.1 This standard deals with the selection of materials, special features of design and construction for earthquake resistant buildings including masonry construction using rectangular masonry units, timber construction and buildings with prefabricated flooring/roofing elements.

1.1.1 Guidelines for earthquake resistant buildings constructed using masonry of low strength and earthen buildings are covered in separate Indian Standards.

2 REFERENCES

The Indian Standards listed below are the necessary adjuncts to this standard:

<i>IS No.</i>	<i>Title</i>
456 : 1978	Code of practice for plain and reinforced concrete (<i>third revision</i>)
883 : 1992	Code of practice for design of structural timber in buildings (<i>fourth revision</i>)
1597 (Part 2) : 1992	Code of practice for construction of stone masonry : Part 2 Ashlar masonry (<i>first revision</i>)
1641 : 1988	Code of practice for fire safety of buildings (general) : General principles of fire grading and classification (<i>first revision</i>)
1642 : 1989	Code of practice for fire safety of buildings (general) : Details of construction (<i>first revision</i>)
1643 : 1988	Code of practice for fire safety of buildings (general) : Exposure hazard (<i>first revision</i>)
1644 : 1988	Code of practice for fire safety of buildings (general) : Exit requirements and personal hazard (<i>first revision</i>)
1646 : 1982	Code of practice for fire safety of buildings (general) : Electrical installations (<i>first revision</i>)
1893 : 1984	Criteria for earthquake resistant design of structures (<i>fourth revision</i>)

*IS No.**Title*

1904 : 1986	Code of practice for design and construction of foundations in soils : General requirements (<i>third revision</i>)
1905 : 1987	Code of practice for structural use of unreinforced masonry (<i>third revision</i>)
2212 : 1991	Code of practice for brickwork (<i>first revision</i>)
2751 : 1979	Recommended practice of welding mild steel plain and deformed bars for reinforced construction (<i>first revision</i>)
3414 : 1968	Code of practice for design and installation of joints in buildings
9417 : 1989	Recommendations for welding cold worked bars for reinforced steel construction (<i>first revision</i>)
13920 : 1993	Code of practice for ductility detailing of reinforced concrete structures subjected to seismic forces

3 TERMINOLOGY

3.0 For the purpose of this standard, the following definitions shall apply.

3.1 Separation Section

A gap of specified width between adjacent buildings or parts of the same building, either left uncovered or covered suitably to permit movement in order to avoid hammering due to earthquake.

3.1.1 Crumple Section

A separation section filled with appropriate material which can crumple or fracture in an earthquake.

3.2 Centre of Rigidity

The point in a structure where a lateral force shall be applied to produce equal deflections of its components at any one level in any particular direction.

3.3 Shear Wall

A wall designed to resist lateral force in its own plane. Braced frames, subjected primarily to axial stresses, shall be considered as shear walls for the purpose of this definition.

3.4 Space Frame

A three-dimensional structural system composed of interconnected members, without shear or bearing walls, so as to function as a complete self-contained unit with or without the aid of horizontal diaphragms or floor bracing systems.

3.4.1 Vertical Load Carrying Frame

A space frame designed to carry all the vertical loads, the horizontal loads being resisted by shear walls.

3.4.2 Moment Resistant Frame

A space frame capable of carrying all vertical and horizontal loads, by developing bending moments in the members and at joints.

3.4.3 Moment Resistant Frame with Shear Walls

A space frame with moment resistant joints and strengthened by shear walls to assist in carrying horizontal loads.

3.5 Box System

A bearing wall structure without a space frame, the horizontal forces being resisted by the walls acting as shear walls.

3.6 Band

A reinforced concrete or reinforced brick runner provided in the walls to tie them together and to impart horizontal bending strength in them.

3.7 Seismic Zone and Seismic Coefficient

The seismic zones I to V as classified in IS 1893 : 1984 and corresponding basic seismic coefficient α_0 as specified in 3.4 of IS 1893 : 1984.

3.8 Design Seismic Coefficient

The value of horizontal seismic coefficient computed taking into account the soil-foundation system and the importance factor as specified in 3.4.2.3(a) of IS 1893 : 1984.

3.9 Concrete Grades

28 day crushing strength of concrete cubes of 150 mm size, in MPa; for example, for Grade M15 of IS 456 : 1978, the concrete strength = 15 MPa.

4 GENERAL PRINCIPLES

4.0 The general principles given 4.1 to 4.9 shall be observed in construction of earthquake resistance buildings.

4.1 Lightness

Since the earthquake force is a function of mass, the building shall be as light as possible consistent with structural safety and functional requirements. Roofs and upper storeys of buildings, in particular, should be designed as light as possible.

4.2 Continuity of Construction

4.2.1 As far as possible, the parts of the building should be tied together in such a manner that the building acts as one unit.

4.2.2 For parts of buildings between separation or crumple sections or expansion joints, floor slabs shall be continuous throughout as far as possible. Concrete slabs shall be rigidly connected or integrally cast with the support beams.

4.2.3 Additions and alterations to the structures shall be accompanied by the provision of separation or crumple sections between the new and the existing structures as far as possible, unless positive measures are taken to establish continuity between the existing and the new construction.

4.3 Projecting and Suspended Parts

4.3.1 Projecting parts shall be avoided as far as possible. If the projecting parts cannot be avoided, they shall be properly reinforced and firmly tied to the main structure, and their design shall be in accordance with IS 1893 : 1984.

4.3.2 Ceiling plaster shall preferably be avoided. When it is unavoidable, the plaster shall be as thin as possible.

4.3.3 Suspended ceiling shall be avoided as far as possible. Where provided they shall be light, adequately framed and secured.

4.4 Building Configuration

4.4.0 In order to minimize torsion and stress concentration, provisions given in 4.4.1 to 4.4.3 should be complied with as relevant.

4.4.1 The building should have a simple rectangular plan and be symmetrical both with respect to mass and rigidity so that the centres of mass and rigidity of the building coincide with each other in which case no separation sections other than expansion joints are necessary. For provision of expansion joints reference may be made to IS 3414 : 1968.

4.4.2 If symmetry of the structure is not possible in plan, elevation or mass, provision shall be made for torsional and other effects due to earthquake forces in the structural design or the parts of different rigidities may be separated through crumple sections. The length of such building between separation sections shall not preferably exceed three times the width.

NOTE — As an alternative to separation section to reduce torsional moments, the centre of rigidity of the building may be brought close or coincident to the centre of mass by adjusting the locations and/or sizes of columns and walls.

4.4.3 Buildings having plans with shapes like, L, T, E and Y shall preferably be separated into rectangular parts by providing separation sections at appropriate places. Typical examples are shown in Fig. 1.

NOTES

1 The buildings with small lengths of projections forming L, T, E or Y shapes need not be provided with separation section. In such cases the length of the projection may not exceed 15 to 20 percent of the total dimension of the building in the direction of the projection (see Fig. 2).

2 For buildings with minor asymmetry in plan and elevation separation sections may be omitted.

4.5 Strength in Various Directions

The structure shall be designed to have adequate strength against earthquake effects along both the horizontal axes. The design shall also be safe considering the reversible nature of earthquake forces.

4.6 Foundations

The structure shall not be founded on such loose soils which will subside or liquefy during an earthquake, resulting in large differential settlements (see also 5.3.3).

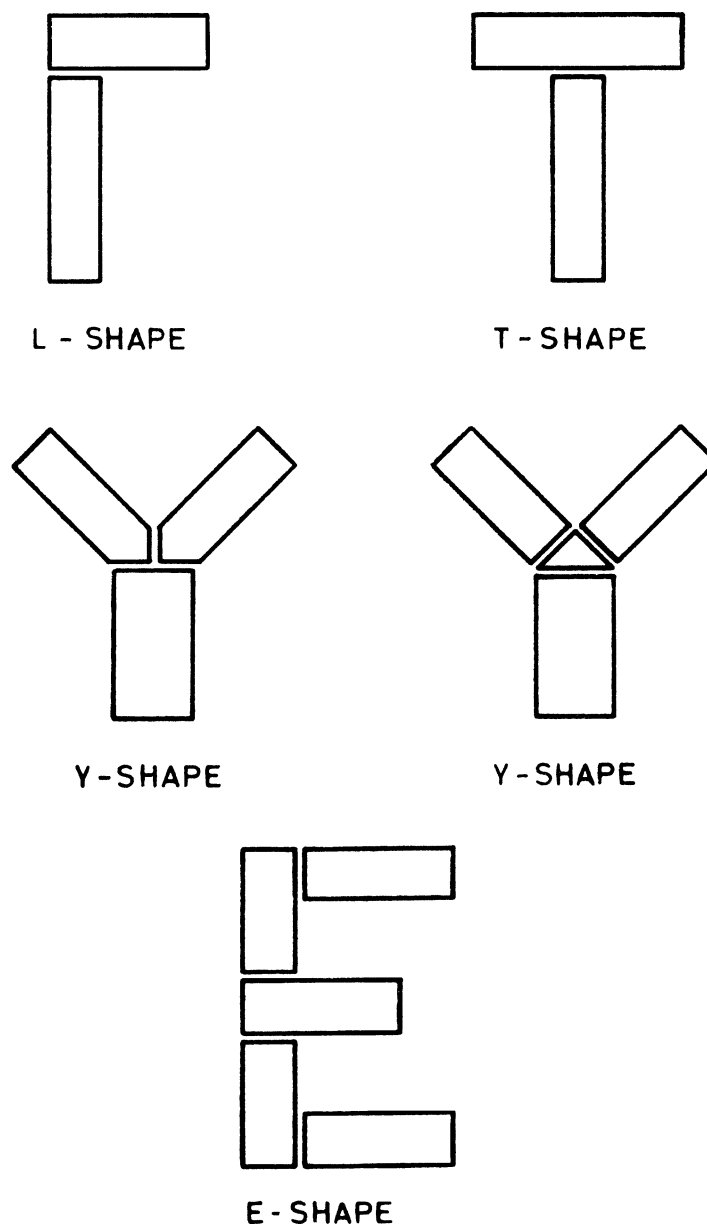

FIG. 1 TYPICAL SHAPES OF BUILDING WITH SEPARATION SECTIONS

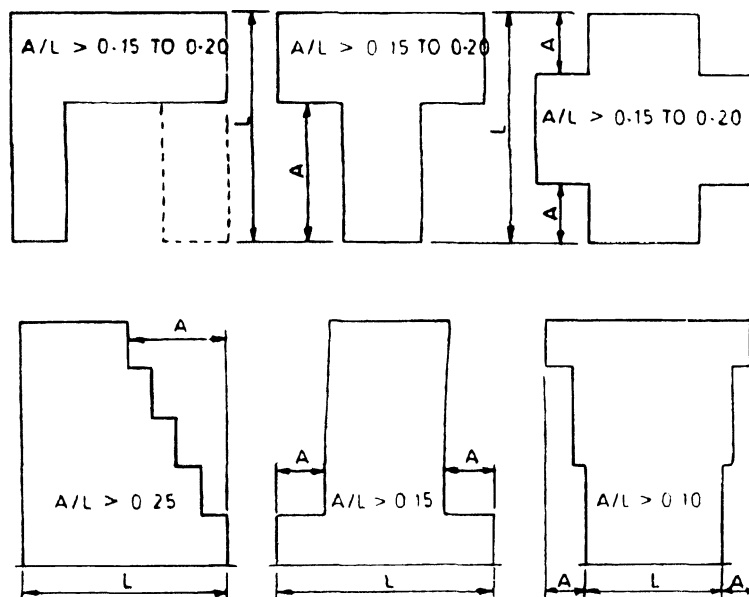

FIG. 2 PLAN AND VERTICAL IRREGULARITIES

4.7 Ductility

The main structural elements and their connection shall be designed to have a ductile failure. This will enable the structure to absorb energy during earthquakes to avoid sudden collapse of the structure. Providing reinforcing steel in masonry at critical sections, as provided in this standard will not only increase strength and stability but also ductility. The details for achieving ductility in reinforced concrete structures is given in IS 13920 : 1993.

4.8 Damage to Non-structural Parts

Suitable details shall be worked out to connect the non-structural parts with the structural framing so that the deformation of the structural frame leads to minimum damage of the non-structural elements.

4.9 Fire Safety

Fire frequently follows an earthquake and therefore, buildings shall be constructed to make them fire resistant in accordance with the provisions of following Indian Standards for fire safety, as relevant: IS 1641 : 1988, IS 1642 : 1989, IS 1643 : 1988, IS 1644 : 1988 and IS 1646 : 1986.

5 SPECIAL CONSTRUCTION FEATURES

5.1 Separation of Adjoining Structures

5.1.1 Separation of adjoining structures or parts of the same structure is required for structures having different total heights or storey heights and different dynamic characteristics. This is to avoid collision during an earthquake.

5.1.2 Minimum width of separation gaps as mentioned in 5.1.1, shall be as specified in Table 1. The design seismic coefficient to be used shall be in accordance with IS 1893 : 1984.

Table 1 Gap Width for Adjoining Structures

Sl No.	Type of Constructions	Gap Width/Storey, in mm for Design Seismic Coefficient $\alpha_h = 0.12$
(1)	(2)	(3)
i)	Box system or frames with shear walls	15.0
ii)	Moment resistant reinforced concrete frame	20.0
iii)	Moment resistant steel frame	30.0

NOTE — Minimum total gap shall be 25 mm. For any other value of α_h the gap width shall be determined proportionately.

5.1.2.1 For buildings of height greater than 40 metres, it will be desirable to carry out model or dynamic analysis of the structures in order to compute the drift at each storey, and the gap width between the adjoining structures shall not be less than the sum of their dynamic deflections at any level.

5.1.3 Where separation is necessary, a complete separation of the parts shall be made except below the plinth level. The plinth beams, foundation beams and footings may be continuous. Where separation sections are provided in a

long building, they shall take care of movement owing to temperature changes also.

5.2 Separation or Crumple Section

5.2.1 In case of framed construction, members shall be duplicated on either side of the separation or crumple section. As an alternative, in certain cases, such duplication may not be provided, if the portions on either side can act as cantilevers to take the weight of the building and other relevant loads.

5.2.2 Typical details of separation and crumple sections are shown in Fig. 3. For other types of joint details, reference may be made to IS 3414 : 1968.

5.3 Foundations

5.3.1 For the design of foundations, the provisions of IS 1904 : 1986 in conjunctions with IS 1893 : 1984 shall generally be followed.

5.3.2 The subgrade below the entire area of the building shall preferably be of the same type of the soil. Wherever this is not possible, a suitably located separation or crumple section shall be provided.

5.3.3 Loose fine sand, soft silt and expansive clays should be avoided. If unavoidable, the building shall rest either on a rigid raft foundation or on piles taken to a firm stratum. However, for light constructions the following measures may be taken to improve the soil on which the foundation of the building may rest:

- a) Sand piling, and
- b) Soil stabilization.

5.3.4 Isolated Footings for Columns

All the individual footings or pile caps where used in Type III Soft soils (Table 3 of IS 1893 : 1984), shall be connected by reinforced concrete ties at least in two directions approximately at right angles to each other. For buildings with no basement the ties may be placed at or below the plinth level and for buildings with basement they may be placed at the level of basement floor. They may be designed to carry the load of the panel walls also.

NOTE — The ties will not be necessary where structural floor connects the columns at or below the plinth level.

5.3.4.1 Where ties are used, their sections shall be designed to carry in tension as well as in compression, an axial load not less than the earthquake force acting on the heavier of the columns connected, but the sections shall not be less than 200 mm × 200 mm with M15 concrete reinforced with 4 bars of 12 mm dia plain mild steel bars or 10 mm dia high strength deformed bars, one at each corner,

bound by 6 mm dia mild steel stirrups not more than 150 mm apart.

NOTE — In working out the buckling strength of ties, the lateral support provided by the soil may be taken into account. Calculations show that for such buried ties, lateral buckling is not a problem and the full section of the tie may be taken effective as a short column.

5.3.4.2 In the case of reinforced concrete slab, the thickness shall not be less than 1/50th of the clear distance between the footings, but not less than 100 mm in any case. It shall be reinforced with not less than 0.15 percent mild steel bars or 0.12 percent high strength deformed bars in each direction placed symmetrically at top and bottom.

5.4 Roofs and Floors

5.4.1 Flat roof or floor shall not preferably be made of terrace of ordinary bricks supported on steel, timber or reinforced concrete joists, nor they shall be of a type which in the event of an earthquake is likely to be loosened and parts of all of which may fall. If this type of construction cannot be avoided, the joists should be blocked at ends and bridged at intervals such that their spacing is not altered during an earthquake.

5.4.1.1 For pitched roofs, corrugated iron or asbestos sheets shall be used in preference to country, Allahabad or Mangalore tiles or other loose roofing units. All roofing materials shall be properly tied to the supporting members. Heavy roofing materials shall generally be avoided.

5.4.2 Pent Roofs

5.4.2.1 All roof trusses shall be supported on reinforced concrete or reinforced brick band (*see 8.4.3*). The holding down bolts shall have adequate length as required for earthquake forces in accordance with IS 1893 : 1984.

Where a trussed roof adjoins a masonry gable, the ends of the purlins shall be carried on and secured to a plate or bearer which shall be adequately bolted to reinforced concrete or reinforced brick band at the top of gable end masonry (*see 8.4.4*).

NOTE — Hipped roof in general have shown better structural behaviour during earthquakes than gable ended roofs.

5.4.2.2 At tie level all the trusses and the gable end shall be provided with diagonal braces in plan so as to transmit the lateral shear due to earthquake force to the gable walls acting as shear walls at the ends as specified in **8.4**.

5.4.3 Jack Arches

Jack arched roofs or floors, where used shall be provided with mild steel ties in all spans alongwith diagonal braces in plan to ensure diaphragms actions.

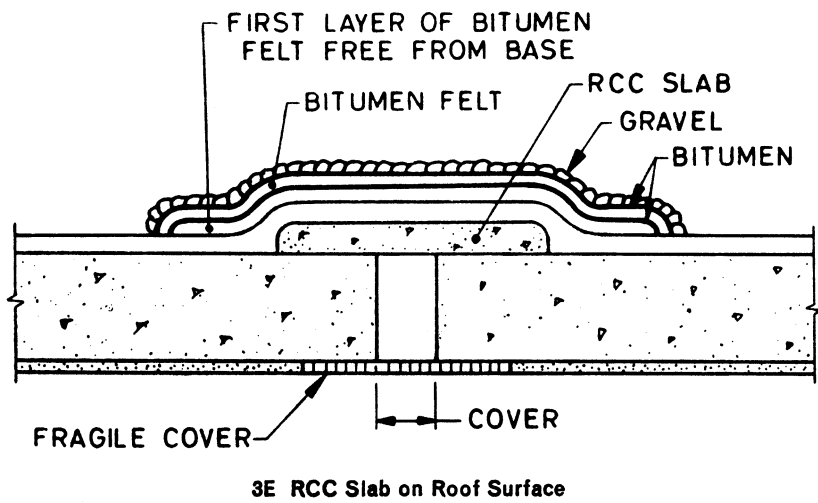
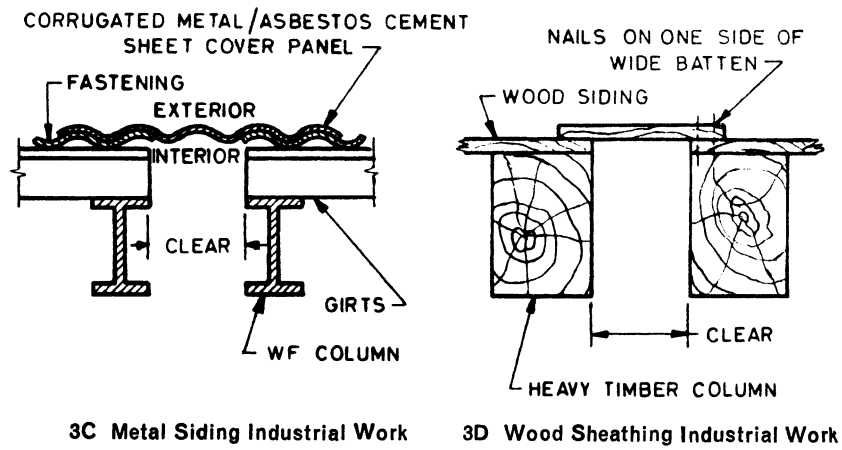
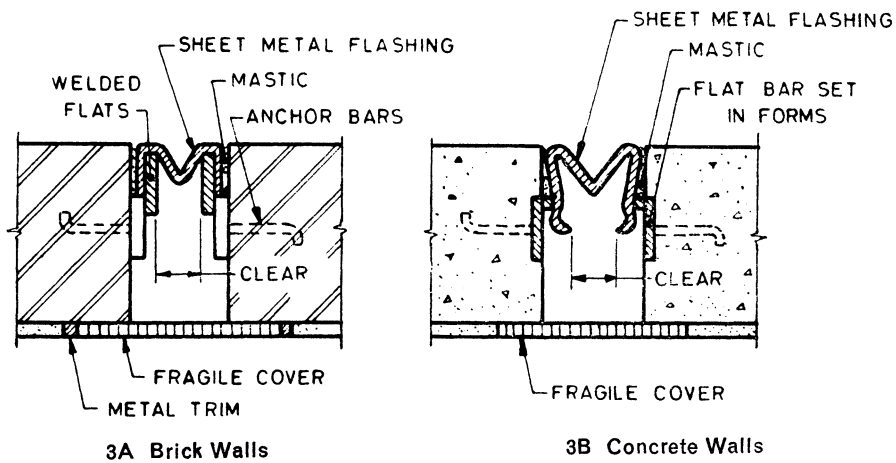

NOTE — Fragile cover may consist of asbestos cement sheet, particle board and the like.

FIG. 3 TYPICAL DETAILS OF SEPARATION OR CRUMPLE SECTION — *Continued*

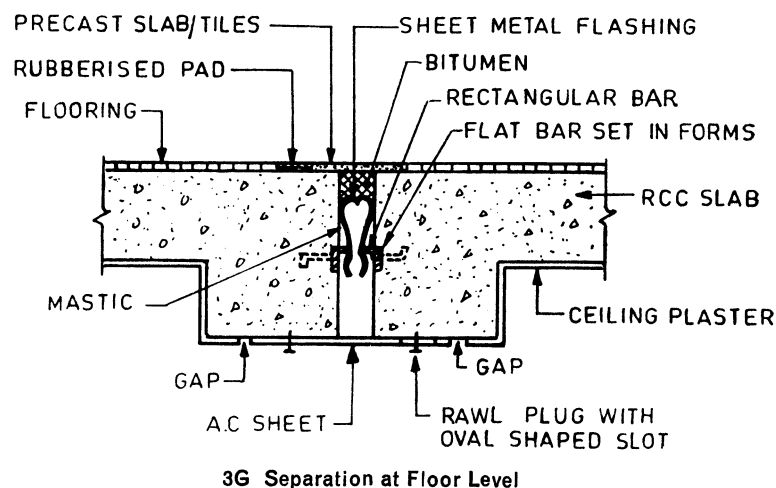
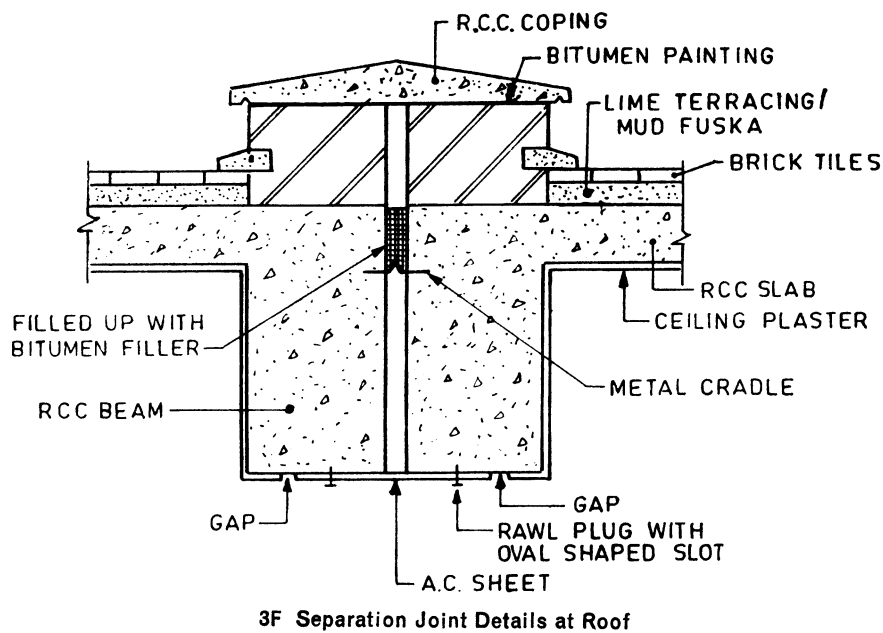

NOTE — Fragile cover may consist of asbestos cement sheet, particle board and like.

FIG. 3 TYPICAL DETAILS OF SEPARATION OR CRUMPLE SECTION

5.5 Staircases

5.5.1 The interconnection of the stairs with the adjacent floors should be appropriately treated by providing sliding joints at the stairs to eliminate their bracing effect on the floors (see 4.5.4). Large stair halls shall preferably be separated from the rest of the building by means of separation or crumple sections.

5.5.2 Three types of stair construction may be adopted as described below:

- i) *Separated Staircases* — One end of the staircase rests on a wall and the other end

is carried by columns and beams which have no connection with the floors. The opening at the vertical joints between the floor and the staircase may be covered either with a tread plate attached to one side of the joint and sliding on the other side, or covered with some appropriate material which could crumple or fracture during an earthquake without causing structural damage. The supporting members, columns or walls, are isolated from the surrounding floors by means of separation or crumple sections. A typical example is shown in Fig. 4.

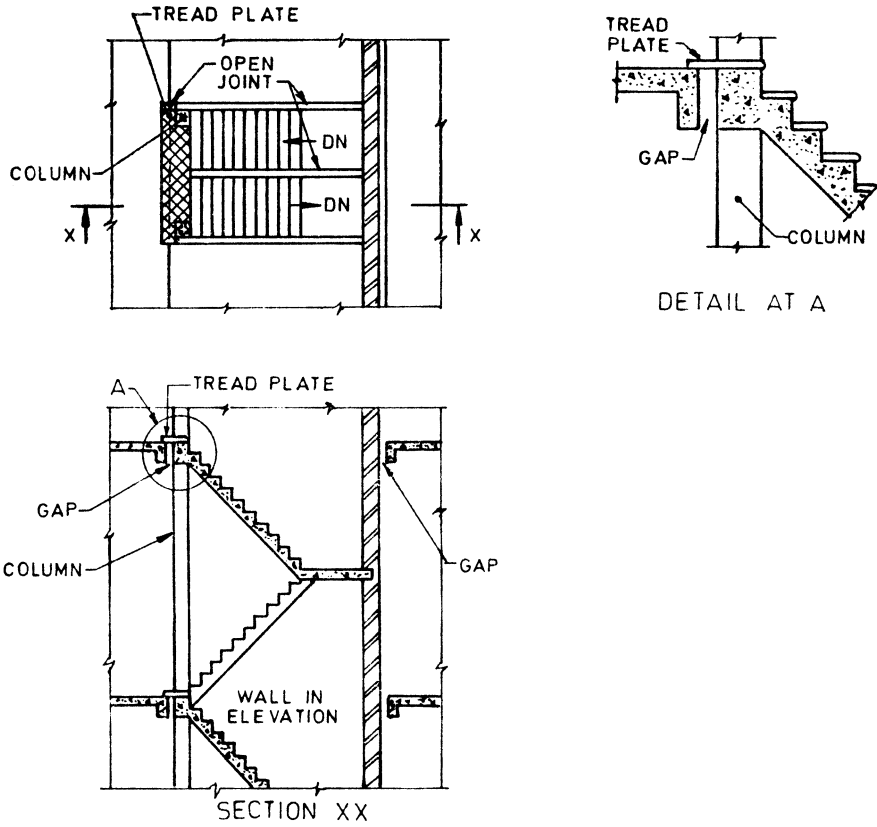

FIG. 4 SEPARATED STAIRCASE

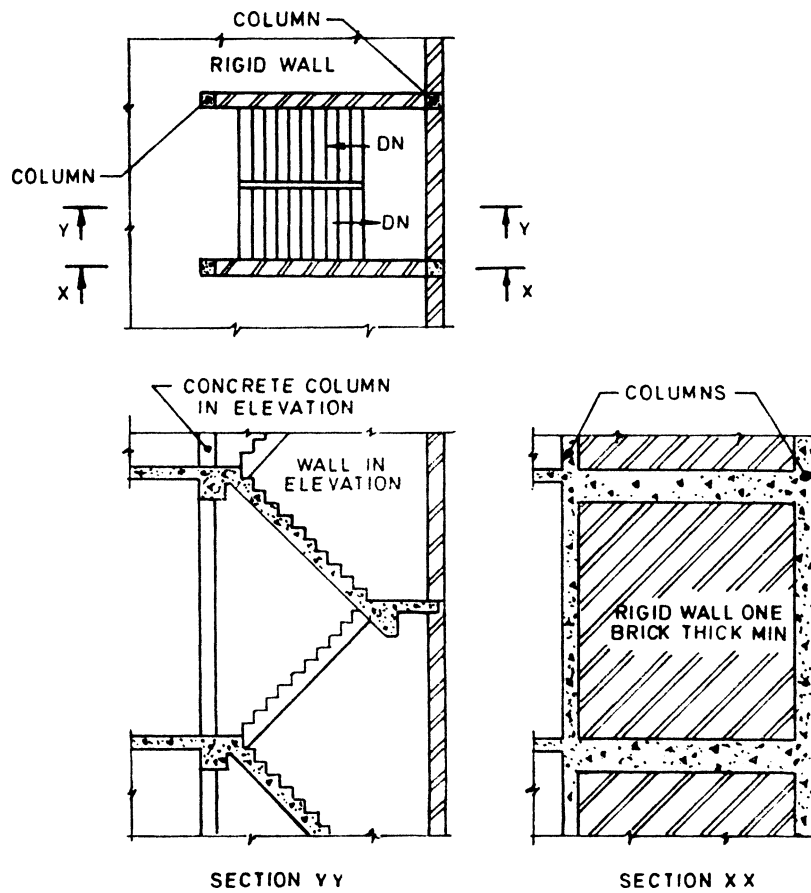

FIG. 5 RIGIDLY BUILT-IN STAIRCASE

- ii) *Built-in Staircase* — When stairs are built monolithically with floors, they can be protected against damage by providing rigid walls at the stair opening. An arrangement, in which the staircase is enclosed by two walls, is given in Fig. 5. In such cases, the joints, as mentioned in respect of separated staircases, will not be necessary.

The two walls mentioned above, enclosing the staircase, shall extend through the entire height of the stairs and to the building foundations.

- iii) *Staircases with Sliding Joints* — In case it is not possible to provide rigid walls around stair openings for built-in staircase or to adopt the separated staircases, the staircases shall have sliding joints so that they will not act as diagonal bracing.

6 TYPES OF CONSTRUCTION

6.1 The types of construction usually adopted in buildings are as follows:

- a) Framed construction, and
- b) Box type construction.

6.2 Framed Construction

This type of construction is suitable for multistoreyed and industrial buildings as described in 6.2.1 and 6.2.2.

6.2.1 Vertical Load Carrying Frame Construction

This type of construction consists of frames with flexible (hinged) joints and bracing members. Steel multistoreyed building or industrial frames and timber construction usually are of this type.

6.2.1.1 Such buildings shall be adequately strengthened against lateral forces by shear walls and/or other bracing systems in plan, elevation and sections such that earthquake forces shall be resisted by them in any direction.

6.2.2 Moment Resistant Frames with Shear Walls

The frames may be of reinforced concrete or steel with semi-rigid or rigid joints. The walls are rigid capable of acting as shear walls and may be of reinforced concrete or of brickwork reinforced or unreinforced bounded by framing members through shear connectors.

6.2.2.1 The frame and wall combination shall be designed to carry the total lateral force due to earthquake acting on the building. The frame acting alone shall be designed to resist at least 25 percent of the total lateral force.

6.2.2.2 The shear walls shall preferably be distributed evenly over the whole building. When concentrated at one point, forming what is called a rigid core in the building, the design shall be checked for torsional effects and the shear connection between the core and the floors conservatively designed for the total shear transfer.

6.2.2.3 The shear walls should extend from the foundation either to the top of the building or to a lesser height as required from design consideration. In design, the interaction between frame and the shear walls should be considered properly to satisfy compatibility and equilibrium conditions.

NOTE — Studies show that shear walls of height about 85 percent of total height of building are advantageous.

6.3 Box Type Construction

This type of construction consists of prefabricated or *in situ* masonry, concrete or reinforced concrete wall along both the axes of the building. The walls support vertical loads and also act as shear walls for horizontal loads acting in any direction. All traditional masonry construction falls under this category. In prefabricated construction attention shall be paid to the connections between wall panels so that transfer of shear between them is ensured.

7 CATEGORIES OF BUILDINGS

7.1 For the purpose of specifying the earthquake resistant features in masonry and wooden buildings, the buildings have been categorized in five categories A to E based on the seismic zone and the importance of building I , where

I = importance factor applicable to the building [see 6.4.2 and Table 6 of IS 1893 (Part 1) : 2002].

7.1.1 The building categories are given in Table 2.

8 MASONRY CONSTRUCTION WITH RECTANGULAR MASONRY UNITS

8.1 The design and construction of masonry walls using rectangular masonry units in general shall be governed by IS 1905 : 1987 and IS 2212 : 1991.

Table 2 Building Categories for Earthquake Resistant Features
(Clause 7.1.1)

Importance Factor	Seismic Zone			
	II	III	IV	V
1.0	B	C	D	E
1.5	C	D	E	E

NOTE — Category A is now defunct as zone I does not exist any more.

8.1.1 Masonry Units

8.1.1.1 Well burnt bricks conforming to IS 1077 : 1992 or solid concrete blocks conforming to IS 2185 (Part 1) : 1979 and having a crushing strength not less than 3.5 MPa shall be used. The strength of masonry unit required shall depend on the number of storeys and thickness of walls (see IS 1905 : 1987).

8.1.1.2 Squared stone masonry, stone block masonry or hollow concrete block masonry, as specified in IS 1597 (Part 2) : 1992 of adequate strength, may also be used.

8.1.2 Mortar

8.1.2.1 Mortars, such as those given in Table 3 or of equivalent specification, shall preferably be used for masonry construction for various categories of buildings.

8.1.2.2 Where steel reinforcing bars are provided in masonry the bars shall be embedded with adequate cover in cement sand mortar not leaner than 1 : 3 (minimum clear cover 10 mm) or in cement concrete of grade M15 (minimum clear cover 15 mm or bar diameter whichever more), so as to achieve good bond and corrosion resistance.

8.2 Walls

8.2.1 Masonry bearing walls built in mortar, as specified in **8.1.2.1** unless rationally designed as reinforced masonry shall not be built of greater height than 15 m subject to a maximum of four storeys when measured from the mean ground level to the roof slab or ridge level. The masonry bearing walls shall be reinforced in accordance with **8.4.1**.

8.2.2 The bearing walls in both directions shall be straight and symmetrical in plan as far as possible.

8.2.3 The wall panels formed between cross walls and floors or roof shall be checked for their strength in bending as a plate or as a vertical strip subjected to the earthquake force acting on its own mass.

NOTE — For panel walls of 200 mm or larger thickness having a storey height not more than 3.5 metres and laterally supported at the top, this check need not be exercised.

Table 3 Recommended Mortar Mixes
(Clauses 8.1.2.1 and 8.2.6)

*Category of Construction	Proportion of Cement-Lime-Sand†
A	M ₂ (Cement-sand 1 : 6) or M ₃ (Lime-cinder‡ 1 : 3) or richer
B, C	M ₂ (Cement-lime-sand 1 : 2 : 9 or Cement-Sand 1 : 6) or richer
D, E	H ₂ (Cement-sand 1 : 4) or M ₁ (Cement-lime-Sand 1 : 1 : 6) or richer

NOTE — Though the equivalent mortar with lime will have less strength at 28 days, their strength after one year will be comparable to that of cement mortar.

*Category of construction is defined in Table 2.

†Mortar grades and specification for types of limes etc, are given in IS 1905 : 1987.

‡In this case some other pozzolanic material like Surkhi (burnt brick fine powder) may be used in place of cinder.

8.2.4 Masonry Bond

For achieving full strength of masonry, the usual bonds specified for masonry should be followed so that the vertical joints are broken properly from course to course. To obtain full bond between perpendicular walls, it is necessary to make a slopping (stepped) joint by making the corners first to a height of 600 mm and then building the wall in between them. Otherwise, the toothed joint should be made in both the walls alternatively in lifts of about 450 mm (see Fig. 6).

8.2.5 Ignoring tensile strength, free standing walls shall be checked against overturning under the action of design seismic coefficient α_h allowing for a factor safety of 1.5.

8.2.6 Panel or filler walls in framed buildings shall be properly bonded to surrounding framing members by means of suitable mortar (see Table 3) or connected through dowels. If the walls are so bonded they shall be checked according to **8.2.3** otherwise as in **8.2.5**.

8.3 Openings in Bearing Walls

8.3.1 Door and window openings in walls reduce their lateral load resistance and hence, should preferably be small and more centrally located. The guidelines on the size and position of opening are given in Table 4 and Fig. 7.

8.3.2 Openings in any storey shall preferably have their top at the same level so that a continuous band could be provided over them, including the lintels throughout the building.

8.3.3 Where openings do not comply with the guidelines of Table 4, they should be strengthened by providing reinforced concrete or reinforcing the brickwork, as shown in Fig. 8 with high

strength deformed (H.S.D.) bars of 8 mm dia but the quantity of steel shall be increased at the jambs to comply with 8.4.9, if so required.

8.3.4 If a window or ventilator is to be projected out, the projection shall be in reinforced masonry or concrete and well anchored.

8.3.5 If an opening is tall from bottom to almost top of a storey, thus dividing the wall into two

portions, these portions shall be reinforced with horizontal reinforcement of 6 mm diameter bars at not more than 450 mm intervals, one on inner and one on outer face, properly tied to vertical steel at jambs, corners or junction of walls, where used.

8.3.6 The use of arches to span over the openings is a source of weakness and shall be avoided. Otherwise, steel ties should be provided.

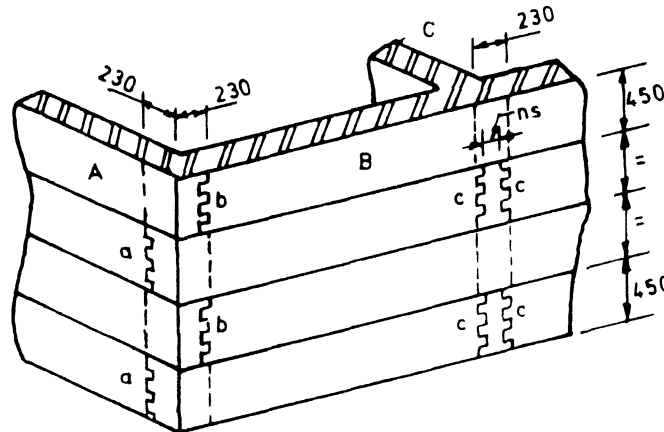

a, b, c = Toothed joints in wall and *A, B, C*

All dimensions in millimetres.

FIG. 6 ALTERNATING TOOTHED JOINTS IN WALLS AT CORNER AND T-JUNCTION

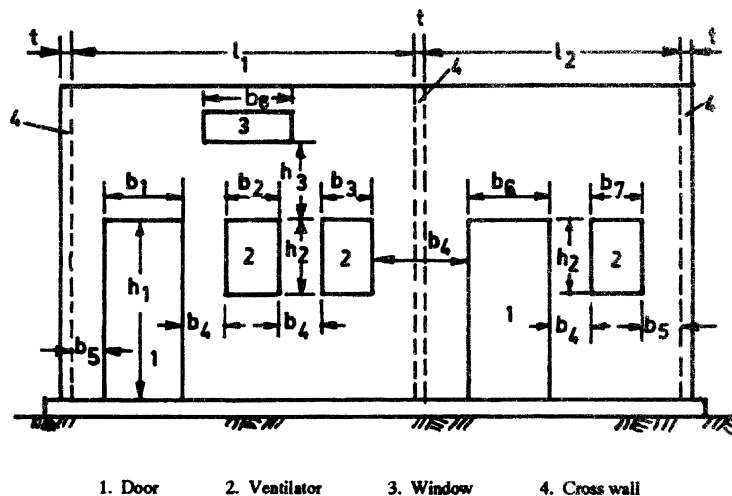

1. Door 2. Ventilator 3. Window 4. Cross wall

FIG. 7 DIMENSIONS OF OPENINGS AND PIERS FOR RECOMMENDATIONS IN TABLE 4

Table 4 Size and Position of Openings in Bearing Walls
(Clause 8.3.1 and Fig. 7)

Sl No.	Position of Opening	Details of Opening for Building Category		
		A and B	C	D and E
1.	Distance b_5 from the inside corner of outside wall, <i>Min</i>	Zero mm	230 mm	450 mm
2.	For total length of openings, the ratio $(b_1 + b_2 + b_3)/l_1$ or $(b_6 + b_7)/l_2$ shall not exceed:			
	a) one-storeyed building	0.60	0.55	0.50
	b) two-storeyed building	0.50	0.46	0.42
	c) 3 or 4-storeyed building	0.42	0.37	0.33
3.	Pier width between consecutive openings b_4 , <i>Min</i>	340 mm	450 mm	560 mm
4.	Vertical distance between two openings one above the other h_3 , <i>Min</i>	600 mm	600 mm	600 mm
5.	Width of opening of ventilator b_8 , <i>Max</i>	900 mm	900 mm	900 mm

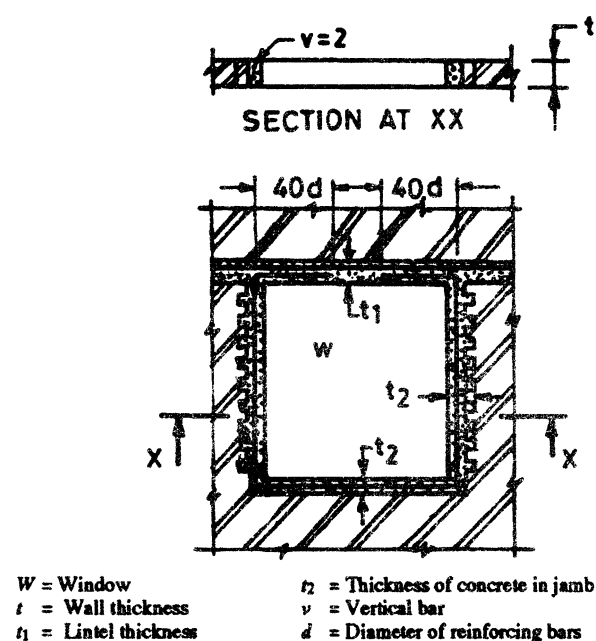

FIG. 8 STRENGTHENING MASONRY AROUND OPENING

8.4 Seismic Strengthening Arrangements

8.4.1 All masonry buildings shall be strengthened by the methods, as specified for various categories of buildings, as listed in Table 5, and detailed in subsequent clauses. Figures 9 and 10 show, schematically, the overall strengthening arrangements to be adopted for category D and E buildings which consist of horizontal bands of reinforcement at critical levels, vertical reinforcing bars at corners, junctions of walls and jambs of opening.

8.4.2 Lintel band is a band (see 3.6) provided at lintel level on all load bearing internal, external longitudinal and cross walls. The specifications of the band are given in 8.4.5.

NOTE — Lintel band if provided in panel or partition walls also will improve their stability during severe earthquake.

8.4.3 Roof band is a band (see 3.6) provided immediately below the roof or floors. The specifications of the band are given in 8.4.5. Such a band need not be provided underneath reinforced concrete or brick-work slabs resting on bearing walls, provided that the slabs are continuous over the intermediate wall up to the crumple sections, if any, and cover the width of end walls, fully or at least 3/4 of the wall thickness.

Table 5 Strengthening Arrangements Recommended for Masonry Buildings (Rectangular Masonry Units)
 (Clause 8.4.1)

Building Category	Number of Storeys	Strengthening to be Provided in all Storeys
(1)	(2)	(3)
A	i) 1 to 3 ii) 4	a a, b, c
B	i) 1 to 3 ii) 4	a, b, c, f, g a, b, c, d, f, g
C	i) 1 and 2 ii) 3 and 4	a, b, c, f, g a to g
D	i) 1 and 2 ii) 3 and 4	a to g a to h
E	1 to 3*	a to h

where

a — Masonry mortar (see 8.1.2),

b — Lintel band (see 8.4.2),

c — Roof band and gable band where necessary (see 8.4.3 and 8.4.4),

d — Vertical steel at corners and junctions of walls (see 8.4.8),

e — Vertical steel at jambs of openings (see 8.4.9),

f — Bracing in plan at tie level of roofs (see 5.4.2.2),

g — Plinth band where necessary (see 8.4.6), and

h — Dowel bars (see 8.4.7).

*4th storey not allowed in category E.

NOTE — In case of four storey buildings of category B, the requirements of vertical steel may be checked through a seismic analysis using a design seismic coefficient equal to four times the one given in (a) 3.4.2.3 of IS 1893 : 1984. (This is because the brittle behaviour of masonry in the absence of a vertical steel results in much higher effective seismic force than that envisaged in the seismic coefficient, provided in the code). If this analysis shows that vertical steel is not required the designer may take the decision accordingly.

8.4.4 Gable band is a band provided at the top of gable masonry below the purlins. The specifications of the band are given in 8.4.5. This band shall be made continuous with the roof band at the eaves level.

8.4.5 Section and Reinforcement of Band

The band shall be made of reinforced concrete of grade not leaner than M15 or reinforced brick-work in cement mortar not leaner than 1 : 3. The bands shall be of the full width of the

wall, not less than 75 mm in depth and reinforced with steel, as indicated in Table 6.

NOTE — In coastal areas, the concrete grade shall be M20 concrete and the filling mortar of 1:3 (cement-sand with water proofing admixture).

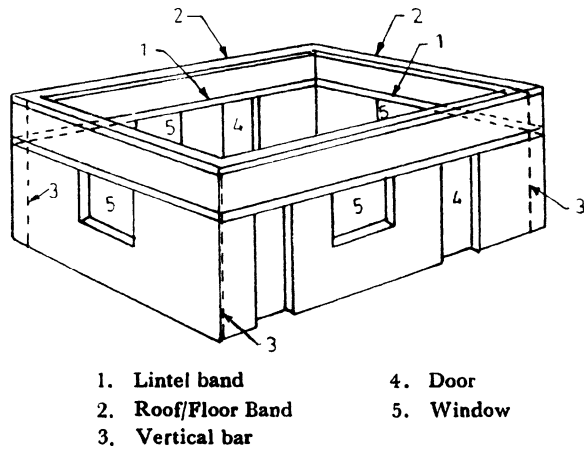

FIG. 9 OVERALL ARRANGEMENT OF REINFORCING MASONRY BUILDINGS

8.4.5.1 In case of reinforced brickwork, the thickness of joints containing steel bars shall be increased so as to have a minimum mortar

cover of 10 mm around the bar. In bands of reinforced brickwork the area of steel provided should be equal to that specified above for reinforced concrete bands.

8.4.5.2 For full integrity of walls at corners and junctions of walls and effective horizontal bending resistance of bands continuity of reinforcement is essential. The details as shown in Fig. 11 are recommended.

8.4.6 Plinth band is a band provided at plinth level of walls on top of the foundation wall. This is to be provided where strip footings of masonry (other than reinforced concrete or reinforced masonry) are used and the soil is either soft or uneven in its properties, as frequently happens in hill tracts. Where used, its section may be kept same as in 8.4.5. This band will serve as damp proof course as well.

8.4.7 In category D and E buildings, to further iterate the box action of walls steel dowel bars may be used at corners and T-junctions of walls at the sill level of windows to length of 900 mm from the inside corner in each wall. Such dowel may be in the form of U stirrups 8 mm dia. Where used, such bars must be laid in 1:3 cement-sand-mortar with a minimum cover of 10 mm on all sides to minimise corrosion.

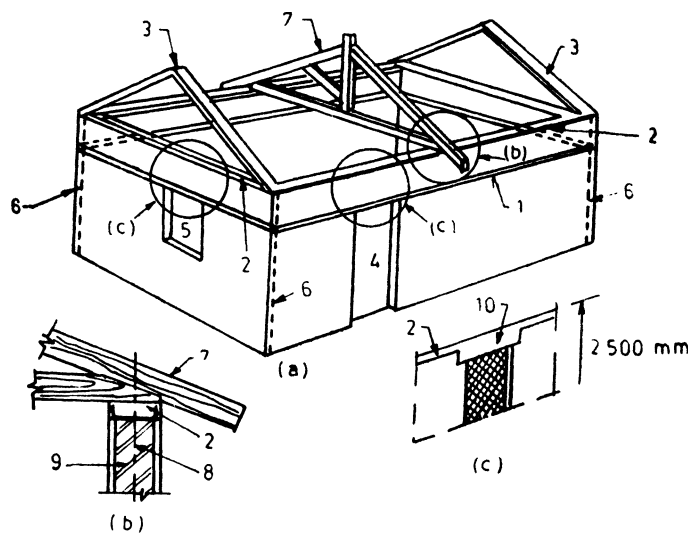

- | | |
|-----------------------------|-----------------------------------------------------|
| 1. Lintel band | 8. Holding down bolt |
| 2. Eave level (Roof) band | 9. Brick/Stone wall |
| 3. Gable band | 10. Door lintel integrated with roof band |
| 4. Door | a) Perspective view |
| 5. Window | b) Details of truss connection with wall |
| 6. Vertical steel bar | c) Detail of integrating door lintel with roof band |
| 7. Rafter | |

FIG. 10 OVERALL ARRANGEMENT OF REINFORCING MASONRY BUILDING HAVING PITCHED ROOF

Table 6 Recommended Longitudinal Steel in Reinforced Concrete Bands
(Clause 8.4.5)

Span	Building Category B		Building Category C		Building Category D		Building Category E	
	No. of Bars	Dia	No. of Bars	Dia	No. of Bars	Dia	No. of Bars	Dia
(1)	(2)	(3)	(4)	(5)	(6)	(7)	(8)	(9)
m		mm		mm		mm		mm
5 or less	2	8	2	8	2	8	2	10
6	2	8	2	8	2	10	2	12
7	2	8	2	10	2	12	4	10
8	2	10	2	12	4	10	4	12

NOTES

1 Span of wall will be the distance between centre lines of its cross walls or buttresses. For spans greater than 8 m it will be desirable to insert pillasters or buttresses to reduce the span or special calculations shall be made to determine the strength of wall and section of band.

2 The number and diameter of bars given above pertain to high strength deformed bars. If plain mild-steel bars are used keeping the same number, the following diameters may be used:

High Strength Def. Bar dia	8	10	12	16	20
Mild Steel Plain bar dia	10	12	16	20	25

3 Width of R.C. band is assumed same as the thickness of the wall. Wall thickness shall be 200 mm minimum. A clear cover of 20 mm from face of wall will be maintained.

4 The vertical thickness of RC band be kept 75 mm minimum, where two longitudinal bars are specified, one on each face; and 150 mm, where four bars are specified.

5 Concrete mix shall be of grade M15 of IS 456 : 1978 or 1 : 2 : 4 by volume.

6 The longitudinal steel bars shall be held in position by steel links or stirrups 6 mm dia spaced at 150 mm apart.

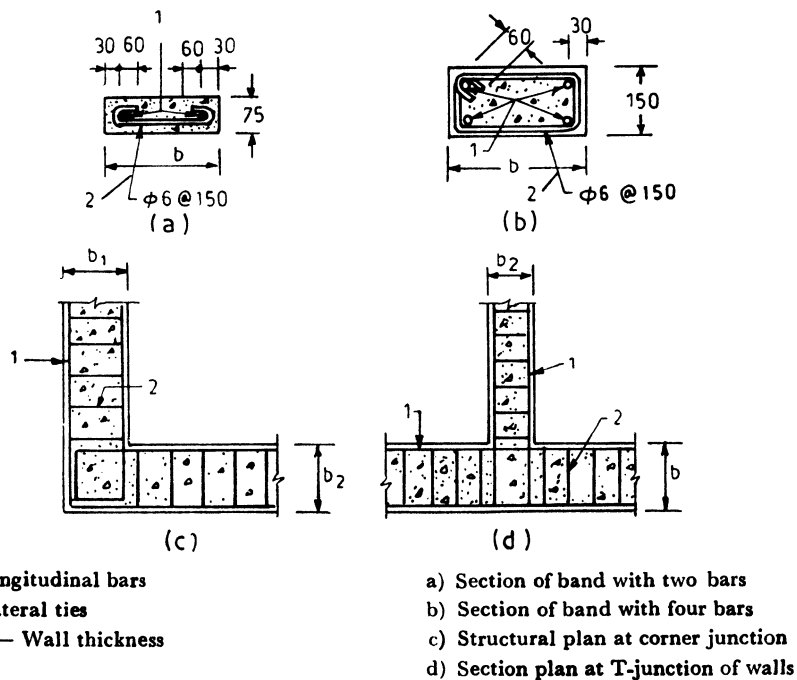

FIG. 11 REINFORCEMENT AND BENDING DETAIL IN R. C. BAND

8.4.8 Vertical Reinforcement

Vertical steel at corners and junctions of walls, which are up to 340 mm ($1\frac{1}{2}$ -brick) thick, shall be provided as specified in Table 7. For

walls thicker than 340 mm the area of the bars shall be proportionately increased. For earthquake resistant framed wall construction, see 8.5. No vertical steel need be provided in category A buildings.

Table 7 Vertical Steel Reinforcement in Masonry Walls with Rectangular Masonry Units

No. of storeys	Storey	Diameter of HSD Single Bar in mm at Each Critical Section			
		Category B	Category C	Category D	Category E
One	—	Nil	Nil	10	12
Two	Top	Nil	Nil	10	12
	Bottom	Nil	Nil	12	16
Three	Top	Nil	10	10	12
	Middle	Nil	10	12	16
	Bottom	Nil	12	12	16
Four	Top	10	10	10	} Four storeyed building not permitted
	Third	10	10	12	
	Second	10	12	16	
	Bottom	12	12	20	

NOTES

1 The diameters given above are for H.S.D. bars. For mild-steel plain bars, use equivalent diameters as given under Table 6 Note 2.

2 The vertical bars will be covered with concrete M15 or mortar 1 : 3 grade in suitably created pockets around the bars (see Fig. 12). This will ensure their safety from corrosion and good bond with masonry.

3 In case of floors/roofs with small precast components, also refer 9.2.3 for floor/roof band details.

8.4.8.1 The vertical reinforcement shall be properly embedded in the plinth masonry of foundations and roof slab or roof band so as to develop its tensile strength in bond. It shall be passing through the lintel bands and floor slabs or floor level bands in all storeys.

Bars in different storeys may be welded (see IS 2751 : 1979 and IS 9417 : 1989, as relevant) or suitably lapped.

NOTE — Typical details of providing vertical steel in brickwork masonry with rectangular solid units at corners and T-junctions are shown in Fig. 12.

8.4.9 Vertical reinforcement at jambs of window and door openings shall be provided as per Table 7. It may start from foundation of floor and terminate in lintel band (see Fig. 8).

8.5 Framing of Thin Load Bearing Walls (see Fig. 13)

Load bearing walls can be made thinner than 200 mm say 150 mm inclusive of plastering on both sides. Reinforced concrete framing columns and collar beams will be necessary to be constructed to have full bond with the walls. Columns are to be located at all corners and junctions of walls and spaced not more than 1.5 m apart but so located as to frame up the doors and windows. The horizontal bands or

ring beams are located at all floors roof as well as lintel levels of the openings. The sequence of construction between walls and columns will be first to build the wall up to 4 to 6 courses height leaving toothed gaps (tooth projection being about 40 mm only) for the columns and second to pour M15 (1 : 2 : 4) concrete to fill the columns against the walls using wood forms only on two sides. The column steel should be accurately held in position all along. The band concrete should be cast on the wall masonry directly so as to develop full bond with it.

Such construction may be limited to only two storeys maximum in view of its vertical load carrying capacity. The horizontal length of walls between cross walls shall be restricted to 7 m and the storey height to 3 m.

8.6 Reinforcing Details for Hollow Block Masonry

The following details may be followed in placing the horizontal and vertical steel in hollow block masonry using cement-sand or cement-concrete blocks.

8.6.1 Horizontal Band

U-shaped blocks may be used for construction of

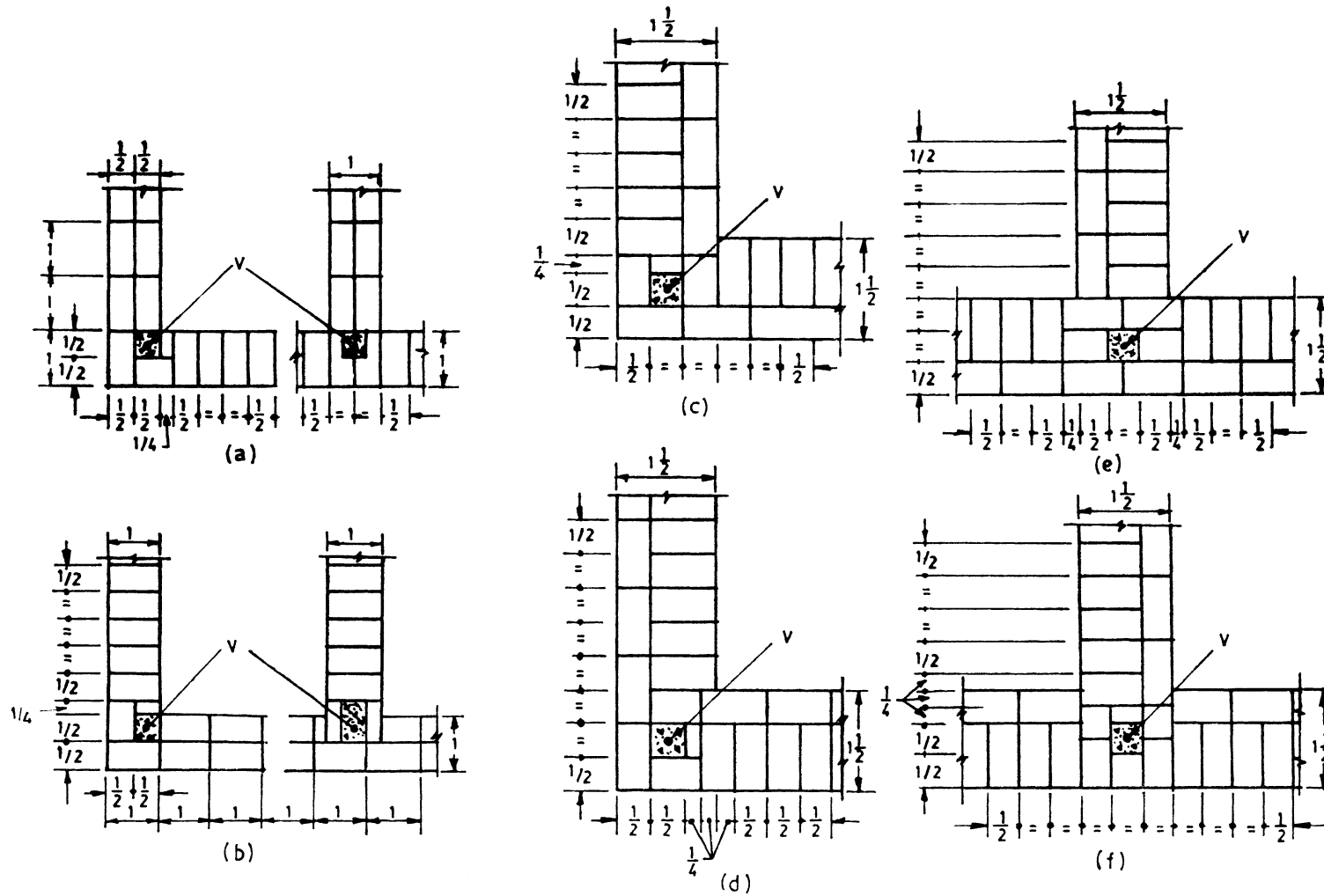

1 — One-brick length, $\frac{1}{2}$ — Half-brick length, V — Vertical steel bar with mortar/concrete filling in pocket.
 (a) and (b) — Alternate courses in one brick wall.
 (c) and (d) Alternate courses at corner junction of $1\frac{1}{2}$ -brick wall.
 (e) and (f) Alternate courses at T-junction of $1\frac{1}{2}$ -brick wall.

FIG. 12 TYPICAL DETAILS OF PROVIDING VERTICAL STEEL BARS IN BRICK MASONRY

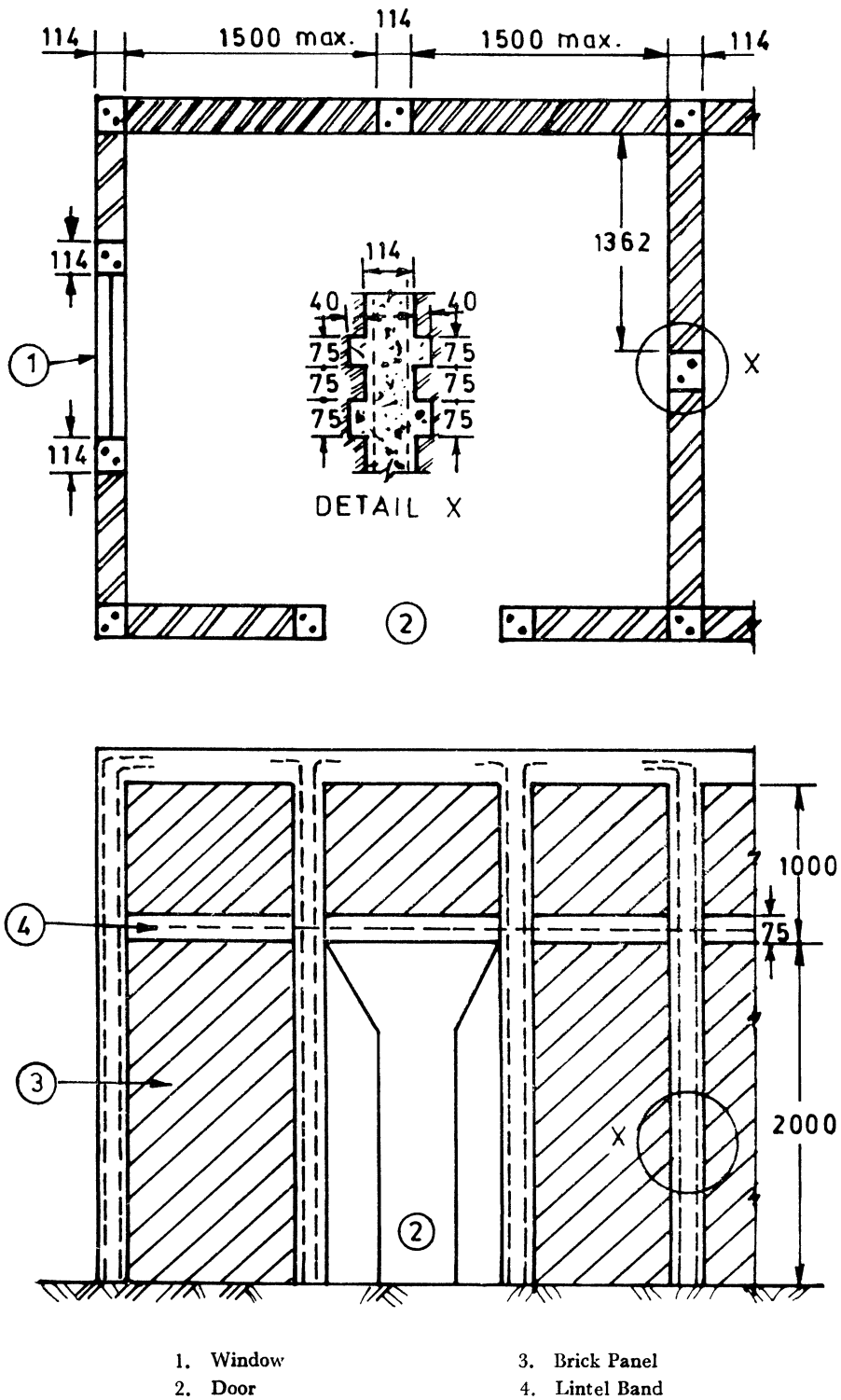

All dimensions in millimetres.

FIG. 13 FRAMING OF THIN LOAD-BEARING BRICK WALLS

horizontal bands at various levels of the storeys as shown in Fig. 14, where the amount of horizontal reinforcement shall be taken 25 percent more than that given in Table 6 and provided by using four bars and 6 mm dia stirrups. Other continuity details shall be followed, as shown in Fig. 11.

8.6.2 Vertical Reinforcement

Bars, as specified in Table 7 shall be located inside the cavities of the hollow blocks, one bar in each cavity (see Fig. 15). Where more than one bar is planned these can be located in two or three consecutive cavities. The cavities containing bars are to be filled by using micro-concrete 1 : 2 : 3 or cement-coarse sand mortar 1 : 3, and properly rodded for compaction. The vertical bars should be spliced

by welding or overlapping for developing full tensile strength. For proper bonding, the overlapped bars should be tied together by winding the binding wire over the lapped length. To reduce the number of overlaps, the blocks may be made U-shaped as shown in Fig. 15 which will avoid lifting and threading of bars into the hollows.

9 FLOORS/ROOFS WITH SMALL PRECAST COMPONENTS

9.1 Types of Precast Floors/Roofs

Earthquake resistance measures for floors and roofs with small precast components, as covered in this standard, have been dealt with as typical examples.

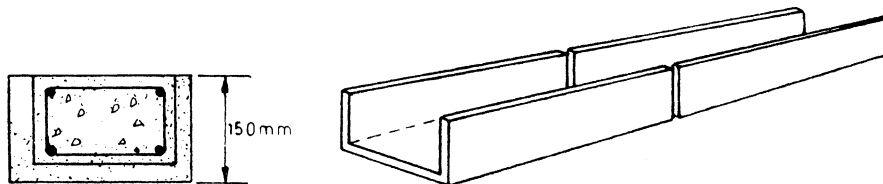

FIG. 14 U-BLOCKS FOR HORIZONTAL BANDS

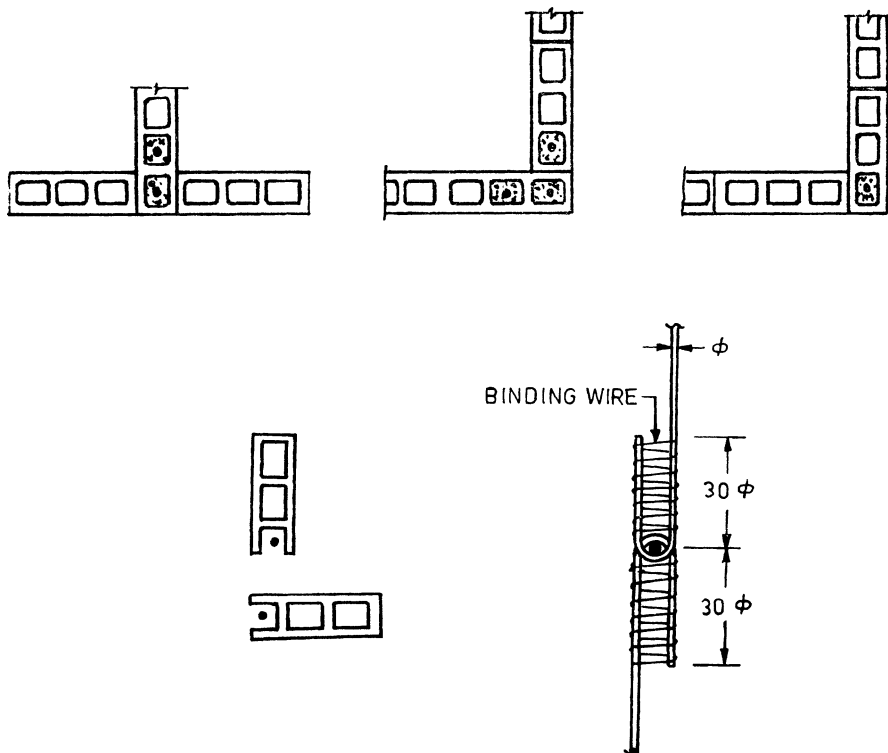

FIG. 15 VERTICAL REINFORCEMENT IN CAVITIES

9.1.1 Precast Reinforced Concrete Unit Roof/Floor

The unit is a precast reinforced concrete component, channel (inverted trough) shaped in section (see Fig. 16). The nominal width of the unit varies from 300 to 600 mm, its height from 150 to 200 mm and a minimum flange thickness of 30 mm. Length of unit shall vary according to room dimensions, but the maximum length is restricted to 4.2 m from stiffness considerations. Horizontal corrugations are provided on the two longitudinal faces of the units so that the structural roof/floor acts monolithic after concrete grouted in the joints between the units attains strength (see Fig. 17).

9.1.2 Precast Reinforced Concrete Cored Unit Roof/Floor

The unit is a reinforced concrete component having a nominal width of 300 to 600 mm and thickness of 130 to 150 mm having two circular hollows 90 mm diameter, throughout the length of the unit (see Fig. 18). The minimum flange/web thickness of the unit shall be 20 mm. Length of unit varies according to room dimensions, but the maximum length shall be restricted to 4.2 m from stiffness considerations. Horizontal corrugations are provided on the two longitudinal faces of the units so that the structural roof/floor acts monolithic after concrete grouted in the joints between the units attains strength (see Fig. 19).

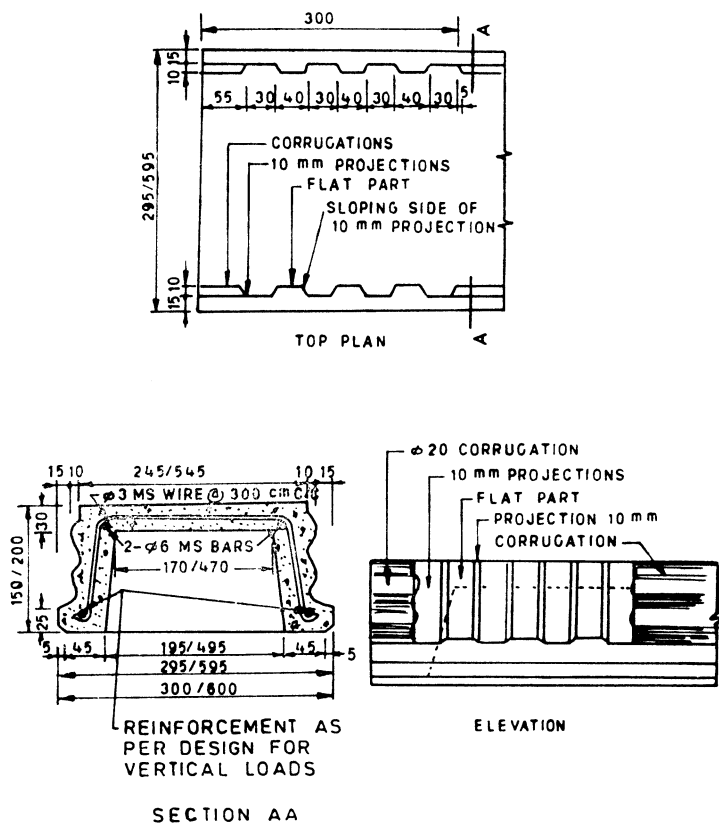

All dimensions in millimetres.

FIG. 16 CHANNEL UNITS

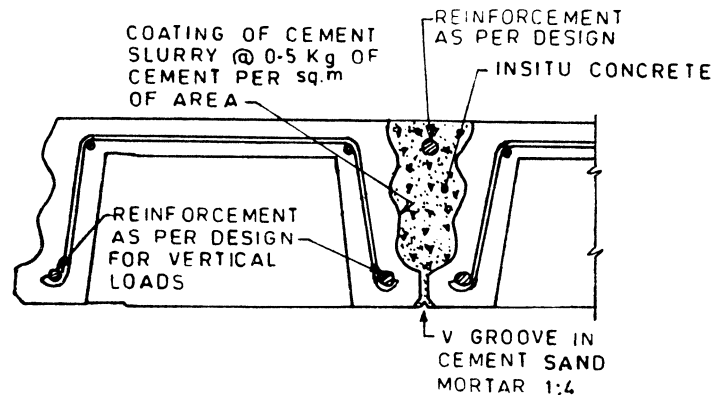
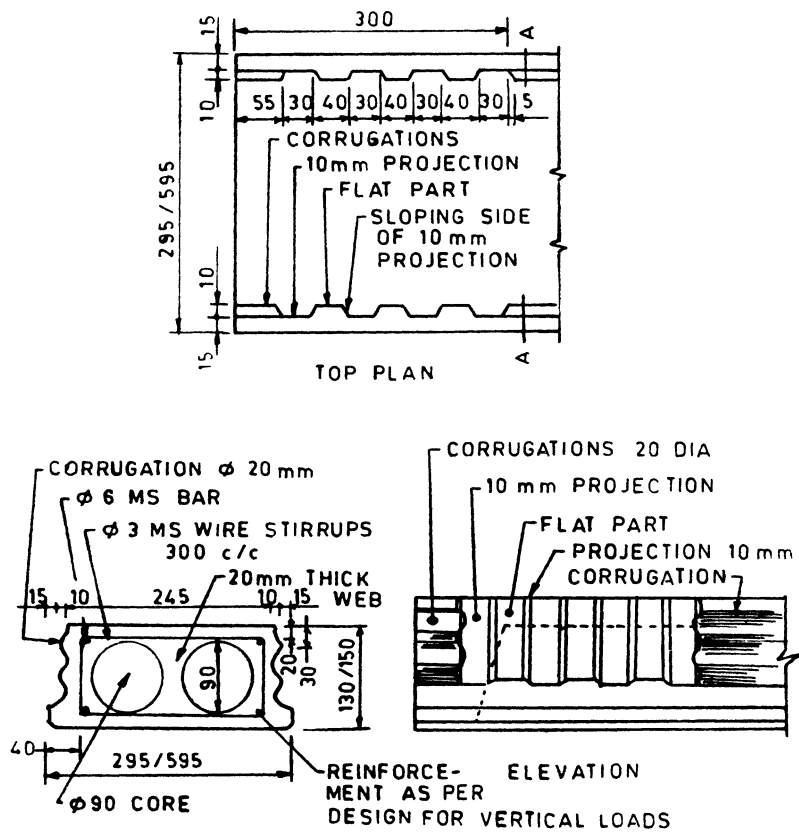
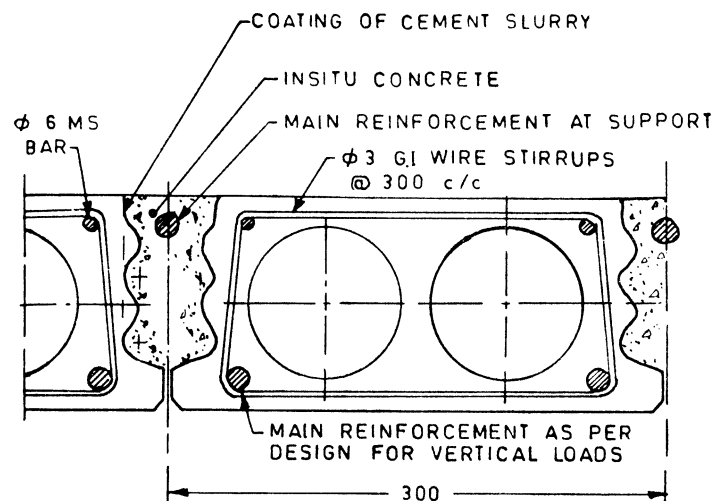

FIG. 17 CHANNEL UNIT FLOOR



All dimensions in millimetres.

FIG. 18 CORE UNITS



All dimensions in millimetres.

FIG. 19 CORED, UNIT FLOOR

9.1.3 Precast Reinforced Concrete Plank and Joist Scheme for Roof/Floor

The scheme consists of precast reinforced concrete planks supported on partially precast reinforced concrete joists. The reinforced concrete planks are 300 mm wide and the length varies according to the spacing of the joists, but it shall not exceed 1.5 m (see Fig. 20). To provide monolithicity to the roof/floor and to have T-beam effect with the joists, the planks shall be made partially 30 mm thick and the partially 60 mm thick and *in-situ* concrete shall be filled in the depressed portions to complete the roof/floor structurally (see Fig. 21).

9.1.4 Prefabricated Brick Panel System for Roof/Floor

It consists of prefabricated reinforced brick panels (see Fig. 22) supported on precast reinforced concrete joists with nominal reinforced 35 mm thick structural deck concrete over the brick panels and joists (see Fig. 23). The width of the brick panels shall be 530 mm for panels made of bricks of conventional size and 450 mm for panels made of bricks of modulus size. The thickness of the panels shall be 75 mm or 90 mm respectively depending upon whether conventional or modular bricks are used. The length of the panels shall vary depending upon the spacing of the joists, but the maximum length shall not exceed 1.2 m.

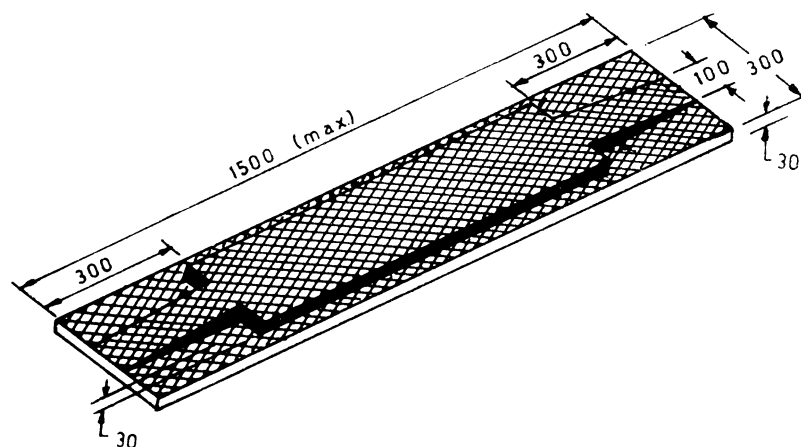

All dimensions in millimetres.

FIG. 20 PRECAST REINFORCED CONCRETE PLANK

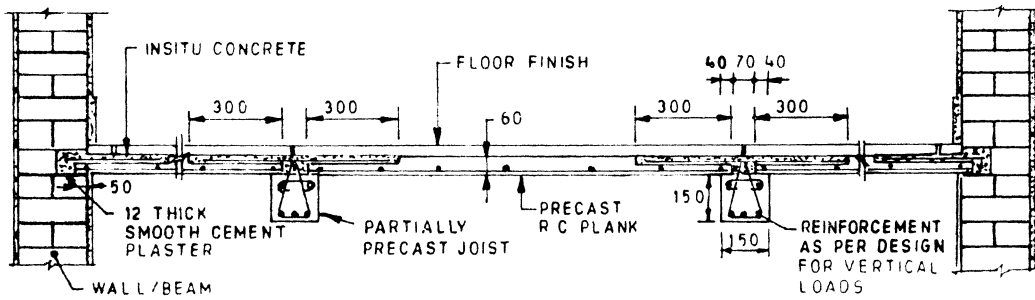

SECTION OF FLOOR

All dimensions in millimetres.

FIG. 21 PRECAST REINFORCED CONCRETE PLANK FLOOR

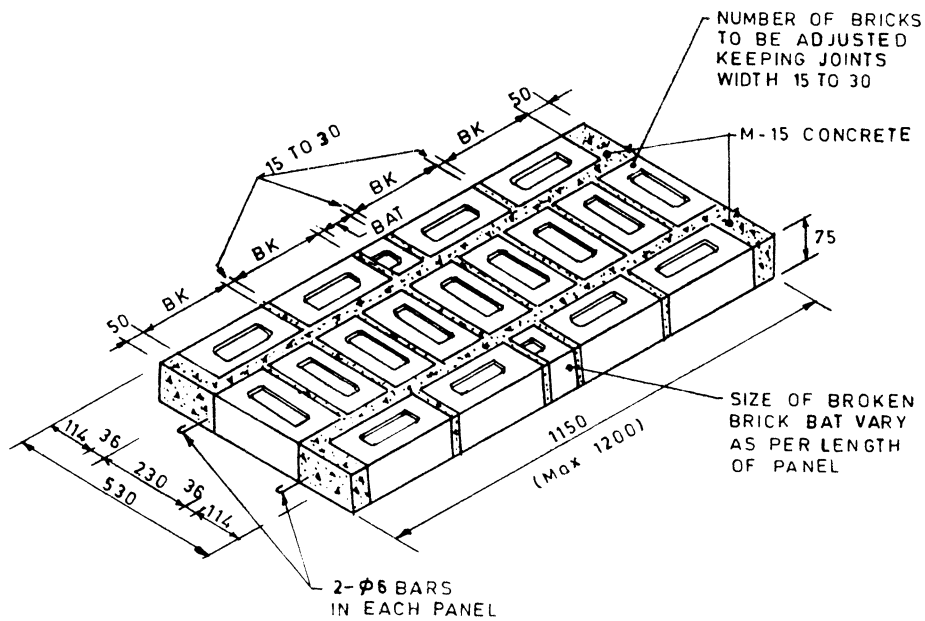

All dimensions in millimetres.

FIG. 22 PREFAB BRICK PANEL

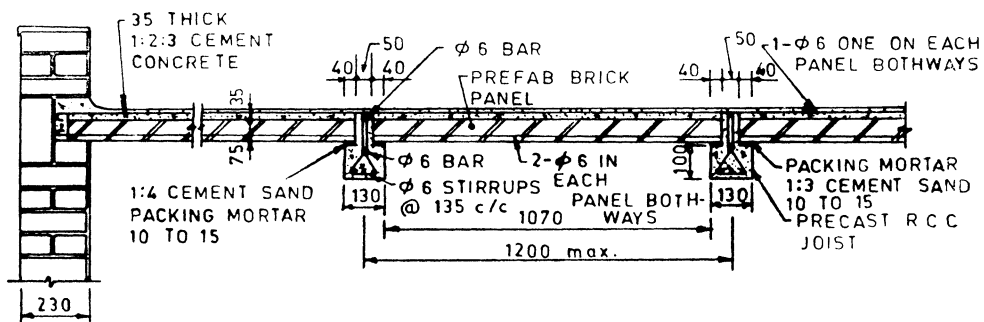

All dimensions in millimetres.

FIG. 23 BRICK PANEL FLOOR

9.1.5 Precast Reinforced Concrete Waffle Unit Roof/Floor

Waffle units are of the shape of inverted troughs, square or rectangular in plan, having lateral dimensions up to 1.2 m and depth depending upon the span of the roof/floor to be covered (see Fig. 24 and 25). The minimum thickness of flange/web shall be 35 mm. Horizontal projections may be provided on all the four external faces of the unit and the unit shall be so shaped that it shall act monolithic with *in-situ* concrete to ensure load transfer. Vertical castallations, called shear keys, shall be provided on all the four external faces of the precast units to enable them to transfer horizontal shear force from one unit to adjacent

unit through *in-situ* concrete filled in the joints between the units. The waffle units shall be laid in a grid pattern with gaps between two adjacent units, and reinforcement, as per design, and structural concrete shall be provided in the gaps between the units in both the directions. The scheme is suitable for two way spanning roofs and floors of buildings having large spans.

9.2 Seismic Resistance Measures

9.2.1 All floors and roofs to be constructed with small precast components shall be strengthened as specified for various categories of buildings in Table 8. The strengthening measures are detailed in 9.2.3 and 9.2.8.

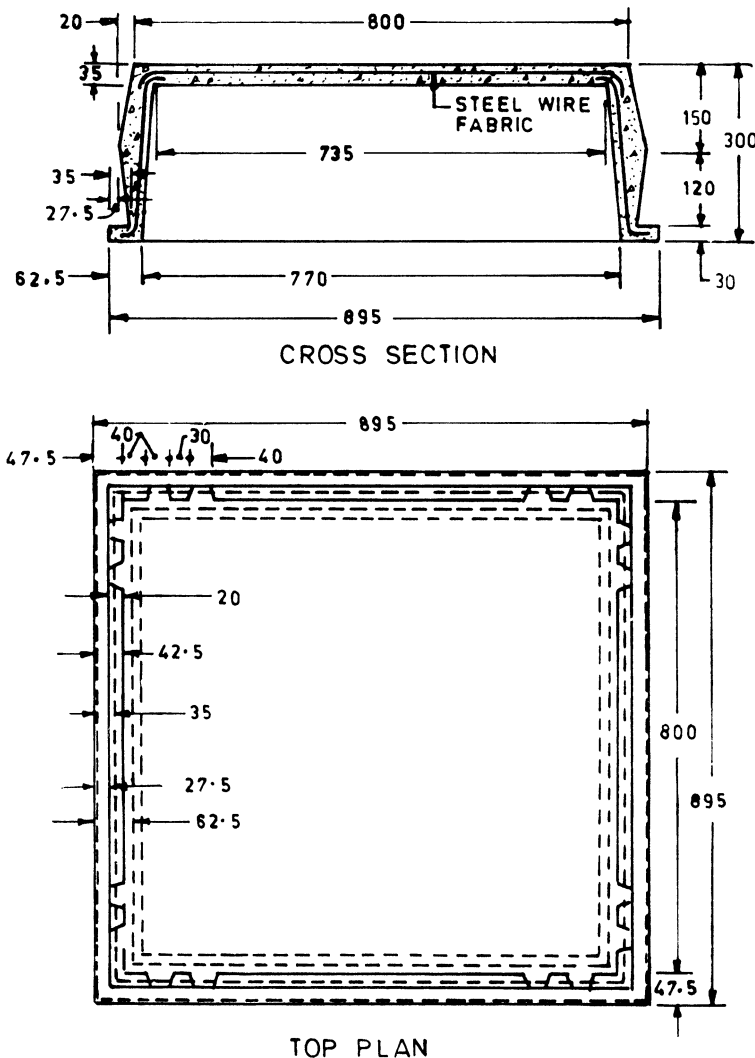

All dimensions in millimetres.

FIG. 24 WAFFLE UNITS

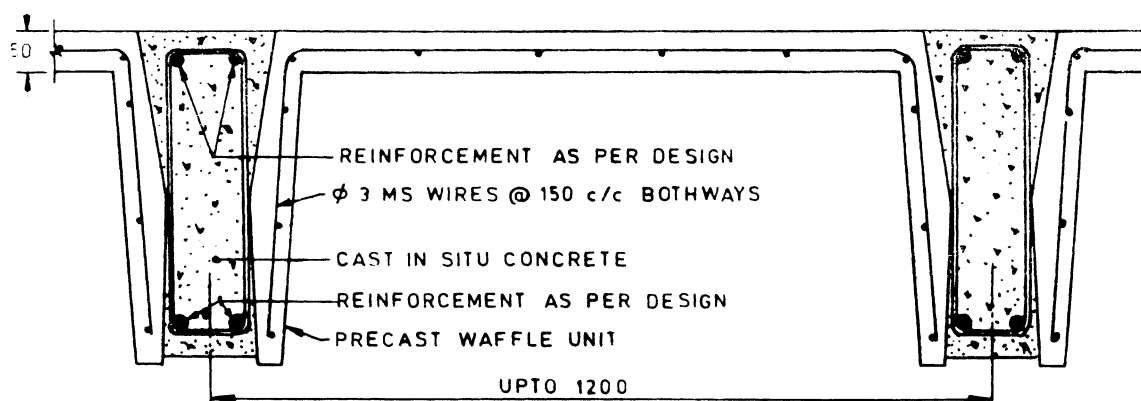

All dimensions in millimetres.

FIG. 25 WAFFLE UNIT FLOOR

9.2.2 Vertical castallations, called shear keys, shall be provided on the longitudinal faces of the channel, cored and waffle units to enable them to transfer horizontal shear force from one unit to the adjacent unit through the *in-situ* concrete filled in the joints between the units. The minimum percentage of area of shear keys as calculated below, on each face of the unit, shall be fifteen.

Shear keys shall have a minimum width of 40 mm at its root with the body of the component and shall be to the full height of the component and preferably at uniform spacing. Percentage of area of shear keys shall be calculated as:

$$\frac{\text{No. of shear keys on one face of the component} \times 40}{\text{Length of the face of the component in mm}} \times 100$$

9.2.3 Tie beam (a in Table 8) is a beam provided all round the floor or roof to bind together all the precast components to make it a diaphragm. The beams shall be to the full width of the supporting wall or beam less the bearing of the precast components. The depth of the beam shall be equal to the depth of the precast components plus the thickness of structural deck concrete, where used over the components. The beam shall be made of cement concrete of grade not leaner than M15 and shall be reinforced as indicated in Table 6. If depth of tie is more than 75 mm, equivalent reinforcement shall be provided with one bar of minimum diameter 8 mm at each corner. Tie beams shall be provided on all longitudinal and cross walls. Typical details of the beams are shown in Fig. 26 to 30.

Table 8 Strengthening Measures for Floors/Roofs with Small Precast Components

(Clauses 9.2.1, 9.2.3, 9.2.4, 9.2.5, 9.2.6, 9.2.7 and 9.2.8)

Building Category	No. of Storeys	Strengthening to be Provided in Floor/Roof with			
		Channel/Cored Unit	R.C. Planks and Joists	Brick Panels and Joists	Waffle Units
(1)	(2)	(3)	(4)	(5)	(6)
A	1 to 3	Nil	Nil	Nil	Nil
	4	a	a	a	a
B	1 to 3	a	a	a	a
	4	a, c	a, c	a, d	a
C	1 & 2	a, b	a	a	a
	3 & 4	a, b, c	a, c	a, d	a, e
D	1 to 4	a, b, c	a, c	a, d	a, c, e
E	1 to 3	a, b, c	a, c	a, d	a, c, e

where

a = Tie beam as per 9.2.3,

b = Reinforcing bars of precast unit and tied to tie beam reinforcement as per 9.2.4,

c = Reinforced deck concrete as per 9.2.5,

d = Reinforced deck concrete as per 9.2.6, and

e = Reinforcement bars in joint between precast waffle units tied to tie beam reinforcement as per 9.2.7.

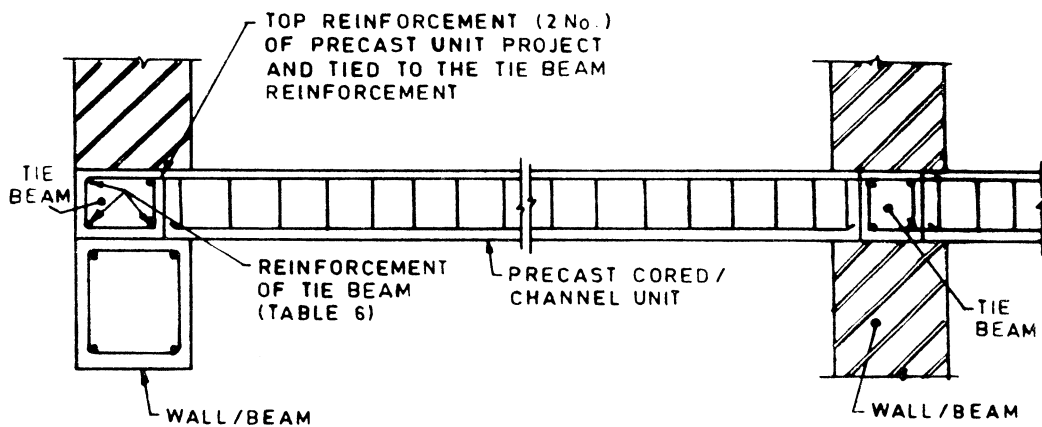
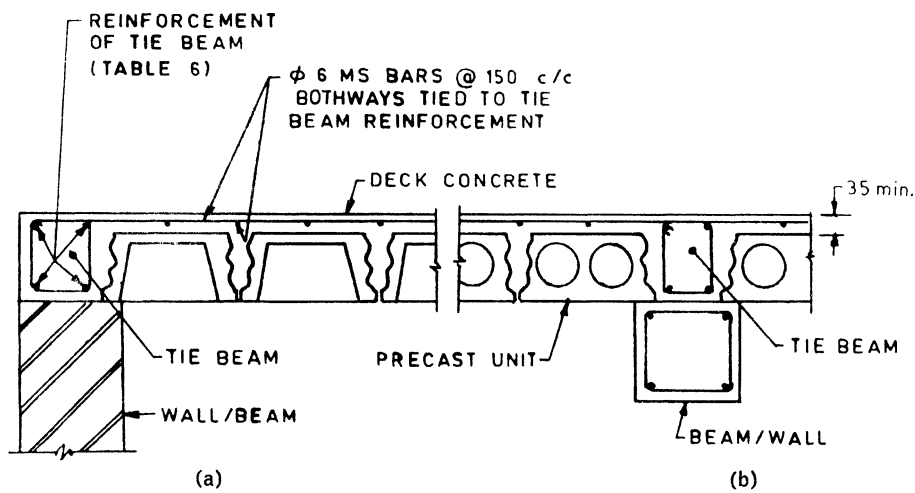

FIG. 26 CONNECTION OF PRECAST CORED/CHANNEL UNIT WITH TIE BEAM



(a)

(b)

a) Channel unit floor/roof

b) Cored unit floor/roof

All dimensions in millimetres.

FIG. 27 CONNECTION OF CHANNEL/CORED UNIT FLOOR/ROOF (WITH DECK CONCRETE) WITH TIE BEAM

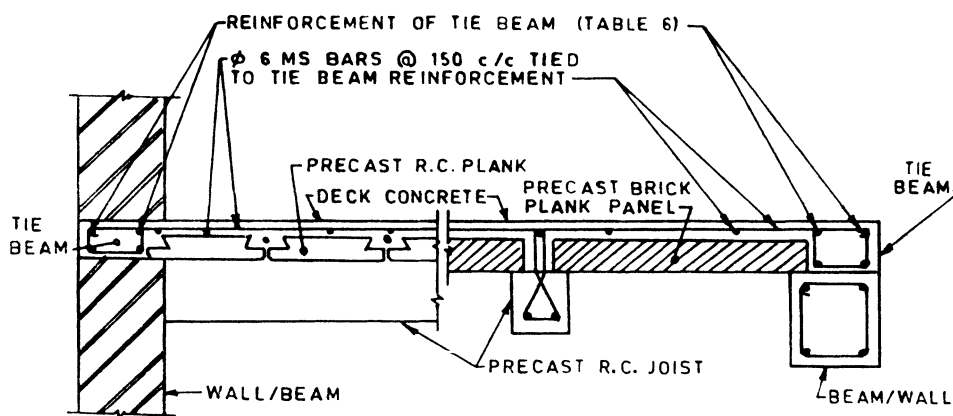

All dimensions in millimetres.

FIG. 28 CONNECTION OF PRECAST REINFORCED CONCRETE PLANK AND PRECAST BRICK PANEL FLOOR/ROOF (WITH DECK CONCRETE) WITH TIE BEAM

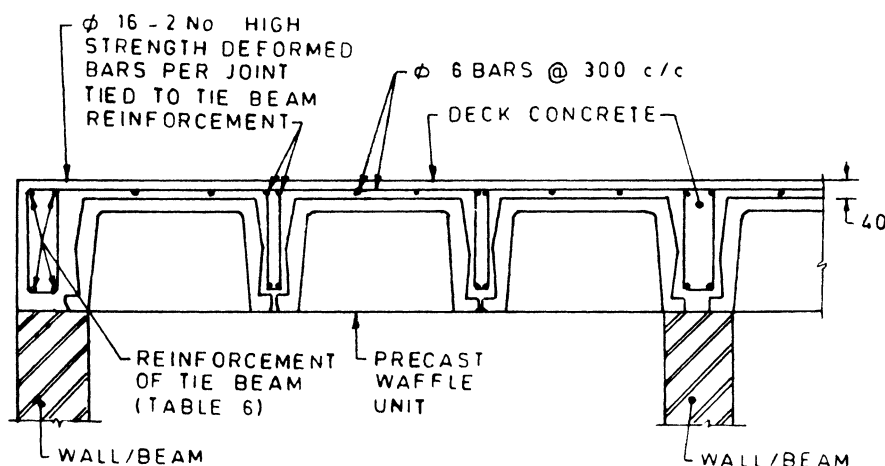

All dimensions in millimetres.

FIG. 29 CONNECTION OF PRECAST WAFFLE UNIT FLOOR/ROOF (WITH DECK CONCRETE) WITH TIE BEAM

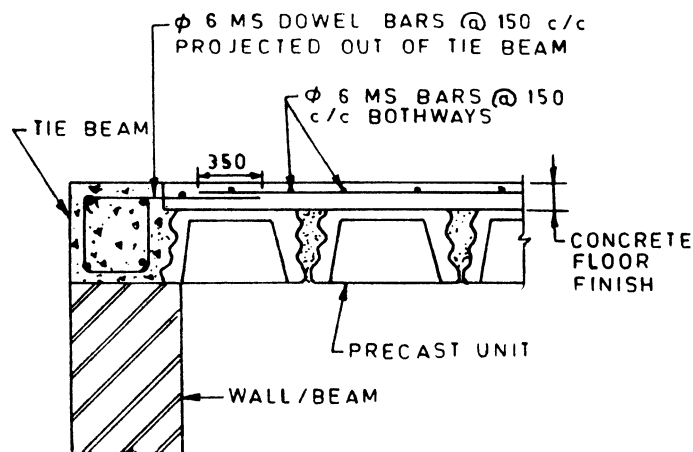

All dimensions in millimetres.

FIG. 30 PROVISION OF REINFORCEMENT IN CONCRETE FLOOR FINISH

9.2.4 Top reinforcement in the channel or cored units (termed B in Table 8) shall be projected out at both the ends for full anchorage length and tied to tie beam reinforcement.

9.2.5 Structural deck concrete (c in Table 8) of grade not leaner than M15 shall be provided over precast components to act monolithic with wherever, deck concrete is to be provided, the top surface of the components shall be finished rough. Cement slurry with 0.5 kg of cement per sq.m of the surface area shall be applied over the components immediately before laying the deck concrete and the concrete shall be compacted using plate vibrators. The minimum thickness of deck concrete shall be 35 or 40 mm reinforced with 6 mm dia bars @ 150 mm apart bothways and anchored into the tie beam placed all round. The maximum size of coarse

aggregate used in deck concrete shall not exceed 12 mm.

NOTE — Under conditions of economic constraints, the deck concrete itself could serve as floor finish. The concrete is laid in one operation (see Fig. 30) without joints.

9.2.6 The deck concrete normally used over the brick panel with joist floor shall be reinforced with 6 mm dia bars spaced 150 mm apart both-ways (d in Table 8).

9.2.7 For floors/roofs with precast waffle units, two 16 mm dia high strength deformed bars shall be provided as top reinforcement in the joints between waffle units, in addition to reinforcement required for taking bending moment for vertical loads. This reinforcement (e in Table 8) shall be fixed to tie beam reinforcement.

9.2.8 In case of floors/roofs with precast components other than those indicated in Table 8, the buildings shall be analysed for maximum expected seismic forces and the floor/roof shall be designed to act as diaphragm and take care of the resulting forces.

10 TIMBER CONSTRUCTION

10.1 Timber has higher strength per unit weight and is, therefore, very suitable for earthquake resistant construction. Materials, design and construction in timber shall generally conform to IS 883 : 1992.

10.2 Timber construction shall generally be restricted to two storeys with or without the attic floor.

10.3 In timber construction attention shall be paid to fire safety against electric short-circuiting, kitchen fire, etc.

10.4 The superstructure of timber buildings shall be made rigid against deformations by adopting suitable construction details at the junctions of the framing members and in wall panels as given in 10.6 to 10.10 so that the construction as a whole behaves as one unit against earthquake forces.

10.5 Foundations

10.5.1 Timber construction shall preferably start above the plinth level, the portion below being in masonry or concrete.

10.5.2 The superstructure may be connected with the foundation in one of the two ways as given in 10.5.2.1 to 10.5.2.2.

10.5.2.1 The superstructure may simply rest on the plinth masonry, or in the case of small buildings of one storey having plan area less than about 50 m², it may rest on firm plane ground so that the building is free to slide laterally during ground motion.

NOTES

1 Past experience has shown that superstructure of the buildings not fixed with the foundation escaped collapse even in a severe earthquake although they were shifted sideways.

2 Where fittings for water supply or water borne sanitation from the house are to be installed, proper attention should be given to permit movement so as to avoid fracture or damage to pipes.

10.5.2.2 The superstructure may be rigidly fixed into the plinth masonry or concrete foundation as given in Fig. 31 or in case of small building having plan area less than 50 m², it may be fixed to vertical poles embedded into the ground. In each case the building is likely to move along with its foundation. Therefore, the superstructure shall be designed to carry the resulting earthquake shears.

10.6 Types of Framing

The types of construction usually adopted in timber buildings are as follows:

- a) Stud wall construction, and
- b) Brick nogged timber frame construction.

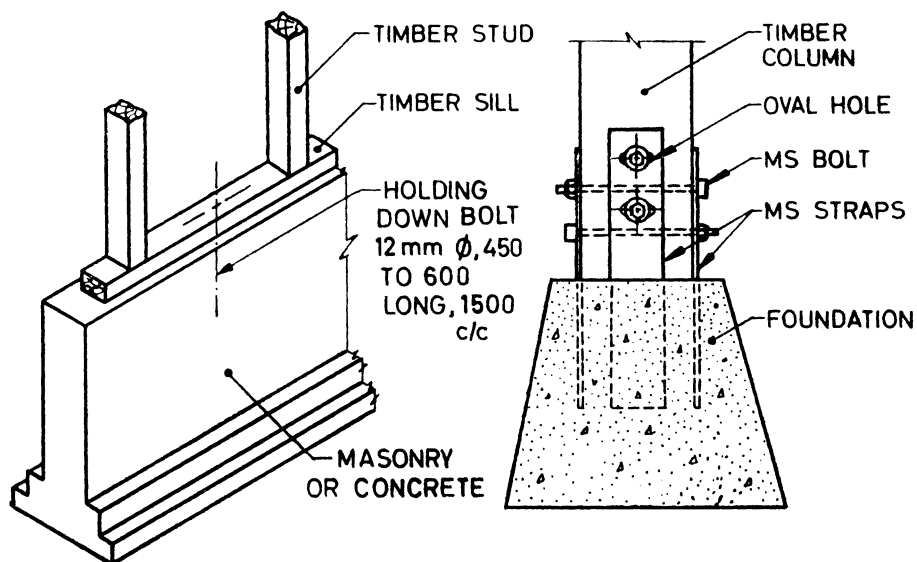

31A Suitable for Strip Foundations 31B Suitable for Isolated Column Footings
 All dimensions in millimetres.

FIG. 31 DETAILS OF CONNECTION OF COLUMN WITH FOUNDATION

10.7 Stud Wall Construction

10.7.1 The stud wall construction consists of timber studs and corner posts framed into sills, top plates and wall plates. Horizontal struts and diagonal braces are used to stiffen the frame against lateral loads. The wall covering may consist of EKRA, timber or like. Typical details of stud walls are shown in Fig. 32. Minimum sizes and spacing of various members used are specified in 10.7.2 to 10.7.10.

10.7.2 The timber studs for use in load bearing walls shall have a minimum finished size of 40 × 90 mm and their spacing shall not exceed those given in Table 9.

10.7.3 The timber studs in non-load bearing walls shall not be less than 40 × 70 mm in finished cross section. Their spacing shall not exceed 1 m.

10.7.4 There shall be at least one diagonal brace for every 1.6 × 1 m area of load bearing walls. Their minimum finished sizes shall be in accordance with Table 10.

10.7.5 The horizontal struts shall be spaced not more than one metre apart. They will have a minimum size of 30 × 40 mm for all locations.

10.7.6 The finished sizes of the sill, the wall plate and top plate shall not be less than the size of the studs used in the wall.

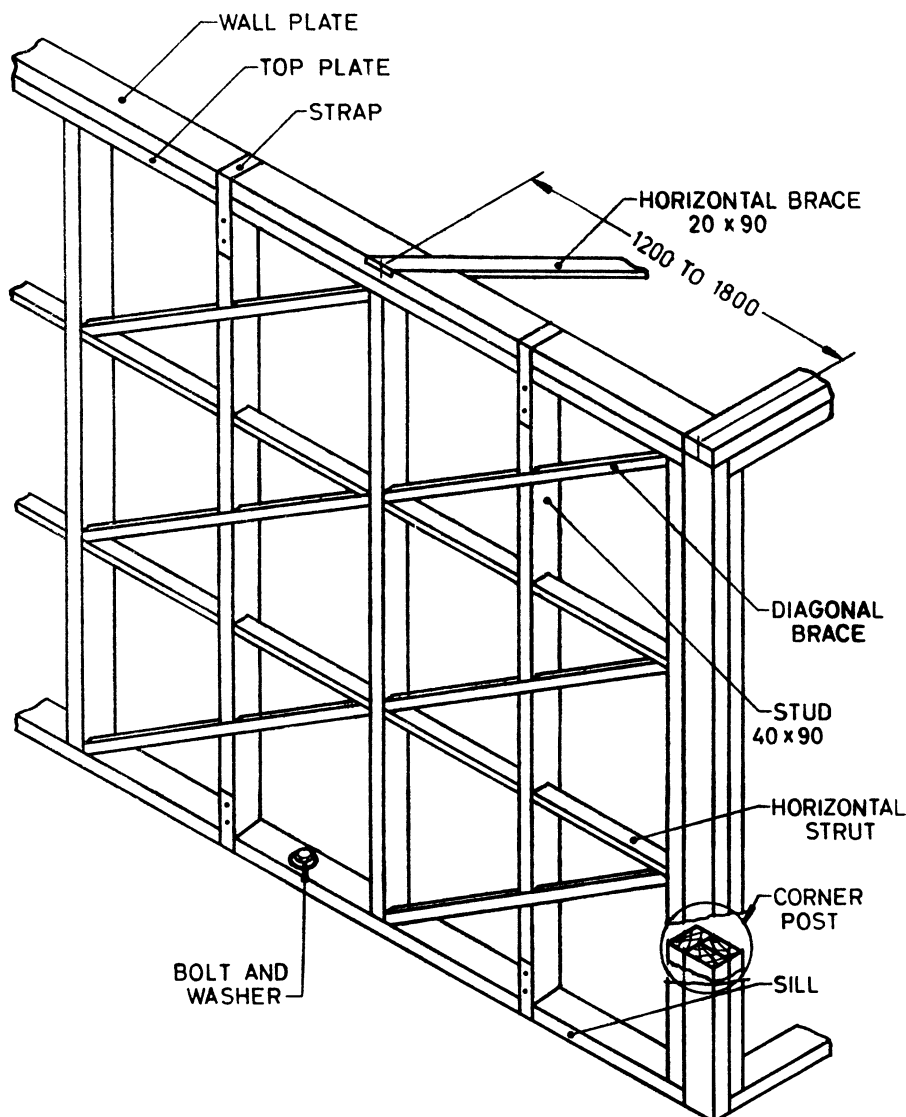

All dimensions in millimetres.

32A Timber Framing in Stud Wall Construction without Opening in Wall

FIG. 32 STUD WALL CONSTRUCTION — Contd

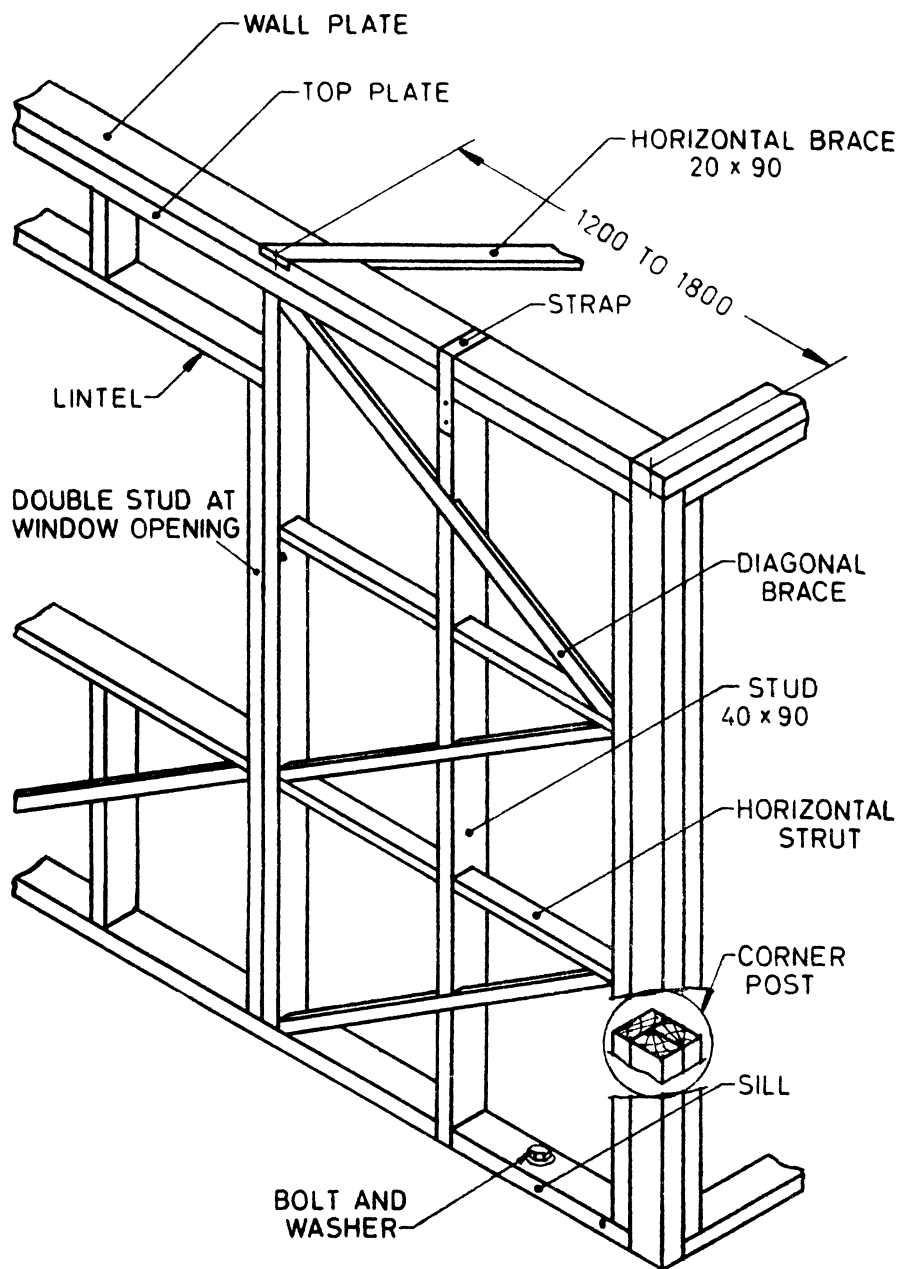

All dimensions in millimetres.

32 B Timber Framing in Stud Wall Construction with Opening in Wall

FIG. 32 STUD WALL CONSTRUCTION

10.7.7 The corner posts shall consist of three timbers, two being equal in size to the studs used in the walls meeting at the corner and the third timber being of a size to fit so as to make a rectangular section (see Fig. 32).

10.7.8 The diagonal braces shall be connected at their ends with the stud wall members by means of wire nails having 6 gauge (4.88 mm dia) and 10 cm length. Their minimum number

shall be 4 nails for 20 mm × 40 mm braces and 6 nails for 30 mm × 40 mm braces. The far end of nails may be clutched as far as possible.

10.7.9 Horizontal bracing shall be provided at corners or T-junctions of walls at sill, first floor and eave levels. The bracing members shall have a minimum finished size of 20 mm × 90 mm and shall be connected by means of wire nails to the wall plates at a distance between

IS 4326 : 1993

1.2 m and 1.8 m measured from the junction of the walls. There shall be a minimum number of six nails of 6 gauge (4.88 mm dia) and 10 cm length with clutching as far ends.

10.7.10 Unsheathed studding shall not be used adjacent to the wall of another building. The studding must be sheathed with close jointed 20 mm or thicker boards.

10.8 Brick Nogged Timber Frame Construction

10.8.1 The brick nogged timber frame consists of intermediate verticals, columns, sills, wall plates, horizontal nogging members and diagonal braces framed into each other and the space between framing members filled with tight-fitting brick masonry in stretcher bond. Typical details of brick nogged timber frame construction are shown in Fig. 33. Minimum sizes and spacing of various elements used are specified in **10.8.2** to **10.8.9**.

10.8.2 The vertical framing members in brick nogged load bearing walls will have minimum finished sizes as specified in Table 10.

10.8.3 The minimum finished size of the vertical members in non-load bearing walls shall be 40 mm × 100 mm spaced not more than 1.5 m apart.

10.8.4 The sizes of diagonal bracing members shall be the same as in Table 10.

10.8.5 The horizontal framing members in brick-nogged construction shall be spaced not more than 1 m apart. Their minimum finished sizes shall be in accordance with Table 12.

10.8.6 The finished sizes of the sill, wall plate and top plate shall be not less than the size of the vertical members used in the wall.

10.8.7 Corner posts shall consist of three vertical timbers as described in **10.7.7**.

10.8.8 The diagonal braces shall be connected at their ends with the other members of the wall by means of wire nails as specified in **10.7.8**.

10.8.9 Horizontal bracing members at corners or T-junctions of wall shall be as specified in **10.7.9**.

Table 9 Maximum Spacing of 40 mm × 90 mm Finished Size Studs in Stud Wall Construction
(Clause 10.7.2)

Group of Timber (Grade I*)	Single Storeyed or First Floor of the Double Storeyed Buildings		Ground Floor of Double Storeyed Buildings	
	Exterior Wall	Interior Wall	Exterior Wall	Interior Wall
	(2)	(3)	(4)	(5)
(1)	cm	cm	cm	cm
Group A, B	100	80	50	40
Group C	100	100	50	50

*Grade I timbers as defined in Table 5 of IS 883 : 1992.

Table 10 Minimum Finished Sizes of Diagonal Braces
(Clauses 10.7.4 and 10.8.4)

Building Category (see Table 2)	Group of Timber (Grade I*)	Single Storeyed or First Floor of Double Storeyed Buildings		Ground Floor of Double Storeyed Buildings	
		Exterior Wall	Interior Wall	Exterior Wall	Interior Wall
		(3)	(4)	(5)	(6)
(1)	(2)	mm × mm	mm × mm	mm × mm	mm × mm
A, B, C	All	20 × 20	20 × 40	20 × 40	20 × 40
D and E	Group A and B	20 × 40	20 × 40	20 × 40	30 × 40
Group C	Group C	20 × 40	30 × 40	30 × 40	30 × 40

*Grade I timber as defined in Table 5 of IS 883 : 1992.

Table 11 Minimum Finished Sizes of Verticals in Brick Nogged Timber Frame Construction
(Clause 10.8.2)

Spacing (1)	Group of Timber (Grade I*) (2)	Single Storeyed or First Floor of Double Storeyed Buildings		Ground Floor of Double Storeyed Buildings	
		Exterior Wall (3)	Interior Wall (4)	Exterior Wall (5)	Interior Wall (6)
m		mm × mm	mm × mm	mm × mm	mm × mm
1	Group A, B	50 × 100	50 × 100	50 × 100	50 × 100
	Group C	50 × 100	70 × 100	70 × 100	90 × 100
1.5	Group A, B	50 × 100	70 × 100	70 × 100	80 × 100
	Group C	70 × 100	80 × 100	80 × 100	100 × 100

*Grade I timbers as defined in Table 5 of IS 883 : 1992.

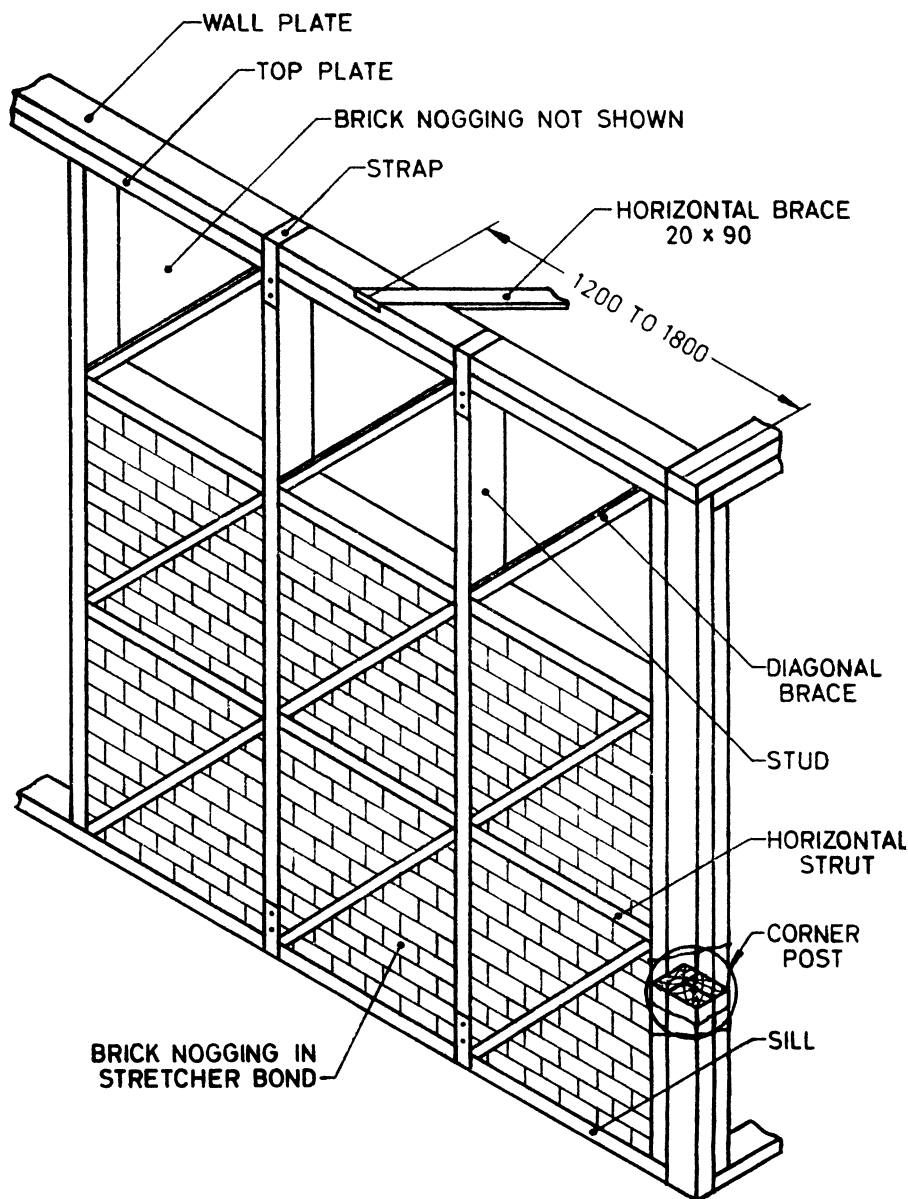

All dimensions in millimetres.

FIG. 33 BRICK NOGGED TIMBER FRAME CONSTRUCTION

Table 12 Minimum Finished size of Horizontal Nogging Members
(Clause 10.8.5)

Spacing of Verticals	Size
(1)	(2)
m	mm
1.5	70 × 100
1	50 × 100
0.5	25 × 100

10.9 Notching and Cutting

10.9.1 Timber framing frequently requires notching and cutting of the vertical members. The notching or cutting should in general be limited to 20 mm in depth unless steel strips are provided to strengthen the notched face of the member. Such steel strips, where necessary, shall be at least 1.5 mm thick and 35 mm wide extending at least 15 cm beyond each side of the notch or cut and attached to the vertical member by means of bolts or screws at each end.

10.9.2 The top plate, the wall plate or the sill of a wall may be notched or cut, if reinforcing

strip of iron is provided as specified in **10.9.1**. In case the member is notched or cut not to exceed 40 mm in depth, such reinforcing strip may be placed along the notched edge only. Where the notch or cut is more than 40 mm in depth or the member is completely cut through, such reinforcing strips shall be placed on both edges of the member. The details of notching and cutting are shown in Fig. 34.

10.9.3 Joints in timber shall preferably be bound by metallic fasteners.

10.10 Bridging and Blocking

10.10.1 All wooden joists shall have at least one row of cross bridging for every 3.5 m length of span. The cross section of the bridging member shall be a minimum of 40 × 70 mm and the member shall be screwed or nailed to the joists.

10.10.2 All spaces between joists shall be blocked at all bearing with solid blocks not less than 40 mm thick and the full depth of the joists. The block shall be screwed or nailed to the joists as well as to the bearings.

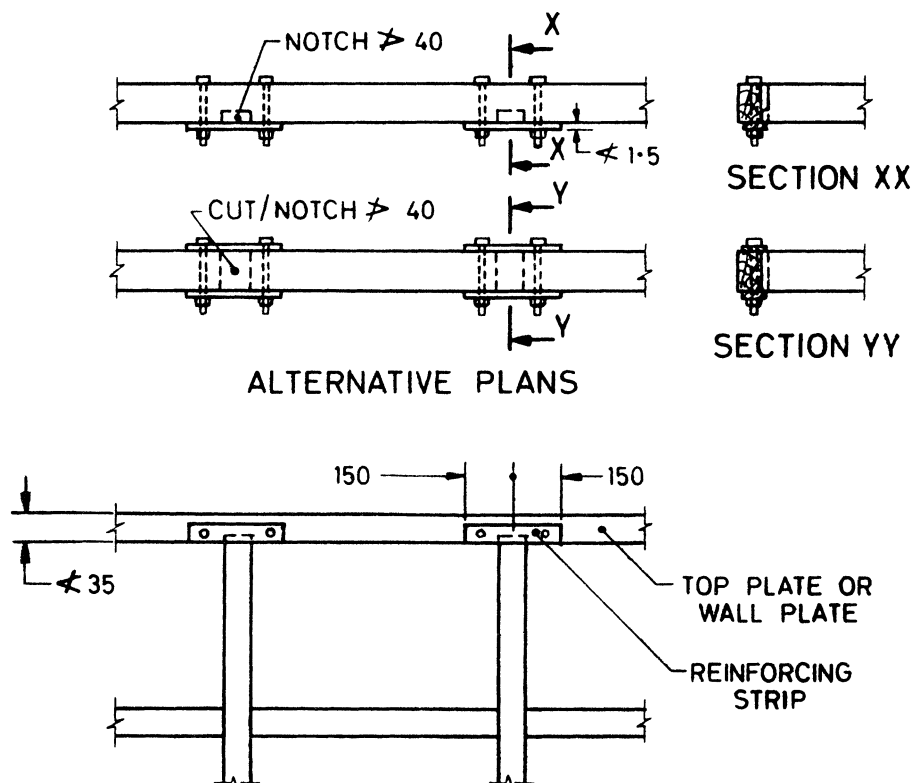

All dimensions in millimetres.
FIG. 34 NOTCHING AND CUTTING

ANNEX A*(Foreword)***COMMITTEE COMPOSITION****Earthquake Engineering Sectional Committee, CED 39***Chairman*DR A. S. ARYA
72/6 Civil Lines, Roorkee*Members*

SHRI O. P. AGGARWAL
SHRI G. SHARAN (*Alternate*)
DR K. G. BHATIA
DR C. KAMESHWARA RAO (*Alternate I*)
SHRI A. K. SINGH (*Alternate II*)
SHRI S. C. BHATIA
DR B. K. RASTOGI (*Alternate*)
DR A. R. CHANDRASEKARAN
DR BRIJESH CHANDRA (*Alternate I*)
DR B. V. K. LAVANIA (*Alternate II*)
DR S. N. CHATTERJEE
SHRI S. K. NAG (*Alternate*)
SHRI K. T. CHAUBAL
DR B. K. PAUL (*Alternate*)
DR A. V. CHUMMAR
DR S. K. KAUSHIK (*Alternate*)
DIRECTOR EMBANKMENT (N & W)
DIRECTOR CMDD (NW & S) (*Alternate*)
DIRECTOR STANDARDS (B & S), RDSO
JOINT DIRECTOR STANDARDS (B & S) CB-I,
RDSO, LUCKNOW (*Alternate*)
MISS E. DIVATIA
SHRI C. R. VENKATESHA (*Alternate*)
SHRI I. D. GUPTA
SHRI J. G. PADALE (*Alternate*)
SHRI V. K. KULKARNI
SHRI P. C. KOTESWARA RAO (*Alternate*)
SHRI V. KUMAR
SHRI R. S. BAJAJ (*Alternate*)
SHRI M. Z. KURIEN
SHRI K. V. SUBRAMANIAN (*Alternate*)
SHRI A. K. LAL
SHRI T. R. BHATIA (*Alternate*)
SHRI S. K. MITTAL
SHRI S. S. NARANG
SHRI A. D. NARIAN
SHRI O. P. AGGARWAL (*Alternate*)
SHRI P. L. NARULA
SHRI A. K. SRIVASTAVA (*Alternate*)
RESEARCH OFFICER
DR D. SENGUPTA
SHRI R. K. GROVER (*Alternate*)
DR R. D. SHARMA
SHRI U. S. P. VERMA (*Alternate*)
COL R. K. SINGH
LT-COL B. D. BHATTOPADHYAYA (*Alternate*)
DR P. SRINIVASULU
DR N. LAKSHMANAN (*Alternate*)
SUPERINTENDING ENGINEER (D)
EXECUTIVE ENGINEER (D) II (*Alternate*)
DR A. N. TANDON
SHRI Y. R. TANEJA,
Director (Civ Engg)

Representing

Indian Roads Congress, New Delhi
Bharat Heavy Electricals Ltd, New Delhi
National Geophysical Research Institute (CSIR), Hyderabad
Department of Earthquake Engineering, University of Roorkee, Roorkee
Indian Meteorological Department, New Delhi
North Eastern Council, Shillong
Indian Society of Earthquake Technology, Roorkee
Central Water Commission (ERDD), New Delhi
Railway Board, Ministry of Railways
National Hydro-Electric Power Corporation Ltd, New Delhi
Central Water & Power Research Station, Pune
Department of Atomic Energy, Bombay
National Thermal Power Corporation Ltd, New Delhi
Tata Consulting Engineers, Bombay
National Buildings Organization, New Delhi
Central Building Research Institute, Roorkee
Central Water Commission (CMDD), New Delhi
Ministry of Transport, Department of Surface Transport (Roads Wing),
New Delhi
Geological Survey of India, Calcutta
Irrigation Department, Govt of Maharashtra, Nasik
Engineers India Ltd, New Delhi
Nuclear Power Corporation, Bombay
Engineer-in-Chief's Branch, Army Headquarters, New Delhi
Structural Engineering Research Centre (CSIR), Madras
Central Public Works Department, New Delhi
In personal capacity (*B-7/50 Safdarjung Development Area, New Delhi*)
Director General, BIS (*Ex-officio Member*)

*Member Secretary*SHRI S. S. SETHI
Director (Civ Engg), BIS*(Continued on page 34)*

IS 4326 : 1993

(Continued from page 33)

Earthquake Resistant Construction Subcommittee, CED 39 : 1

<i>Convener</i>	<i>Representing</i>
DR A. S. ARYA	In personal capacity (72/6 Civil Lines, Roorkee)
<i>Members</i>	
SHRI N. K. BHATTACHARYA	Engineer-in-Chief's Branch, New Delhi
SHRI B. K. CHAKRABORTY	Housing and Urban Development Corporation, New Delhi
SHRI D. P. SINGH (<i>Alternate</i>)	
SHRI D. N. GHOSAL	North Eastern Council, Shillong
DR SUDHIR K. JAIN	Indian Institute of Technology, Kanpur
DR A. S. R. SAI (<i>Alternate</i>)	
SHRI M. P. JAISINGH	Central Buildings Research Institute, Roorkee
JOINT DIRECTOR STANDARDS (B & S) CB-I	Railways Board, Ministry of Railways
ASSTT DIRECTOR (B & S) CB-I (<i>Alternate</i>)	
SHRI V. KAPUR	Public Works Department, Govt of Himachal Pradesh, Shimla
SHRI V. K. KAPOOR (<i>Alternate</i>)	
SHRI M. KUNDU	Hindustan Prefab Limited, New Delhi
SHRI A. K. LAL	National Buildings Organization, New Delhi
SHRI T. R. BHATIA (<i>Alternate</i>)	
DR B. C. MATHUR	University of Roorkee, Department of Earthquake Engineering, Roorkee
DR (MRS) P. R. BOSE (<i>Alternate</i>)	
SHRI G. M. SHOUNTHU	Public Works Department, Jammu & Kashmir
DR P. SRINIVASULU	Structural Engineering Research Centre (CSIR), Madras
DR N. LAKSHMANAN (<i>Alternate</i>)	
SHRI SUBRATA CHAKRAVARTY	Public Works Department, Government of Assam, Guwahati
SUPERINTENDING ENGINEER (DESIGN)	Public Works Department, Government of Gujarat
SUPERINTENDING SURVEYOR OF WORKS (NDZ)	Central Public Works Department, New Delhi
SUPERINTENDING ENGINEER (D) (<i>Alternate</i>)	

Bureau of Indian Standards

BIS is a statutory institution established under the *Bureau of Indian Standards Act*, 1986 to promote harmonious development of the activities of standardization, marking and quality certification of goods and attending to connected matters in the country.

Copyright

BIS has the copyright of all its publications. No part of these publications may be reproduced in any form without the prior permission in writing of BIS. This does not preclude the free use, in the course of implementing the standard, of necessary details, such as symbols and sizes, type or grade designations. Enquiries relating to copyright be addressed to the Director (Publications), BIS.

Review of Indian Standards

Amendments are issued to standards as the need arises on the basis of comments. Standards are also reviewed periodically; a standard along with amendments is reaffirmed when such review indicates that no changes are needed; if the review indicates that changes are needed, it is taken up for revision. Users of Indian Standards should ascertain that they are in possession of the latest amendments or edition by referring to the latest issue of 'BIS Catalogue' and 'Standards : Monthly Additions'.

This Indian Standard has been developed from Doc : No. CED 39 (5267).

Amendments Issued Since Publication

Amend No.	Date of Issue
Amd. No. 1	December 1995
Amd. No. 2	April 2002
Amd. No. 3	January 2005

BUREAU OF INDIAN STANDARDS

Headquarters:

Manak Bhavan, 9 Bahadur Shah Zafar Marg, New Delhi 110002.
Telephones: 323 01 31, 323 33 75, 323 94 02

Telegrams: Manaksanstha
(Common to all offices)

Regional Offices:

Central : Manak Bhavan, 9 Bahadur Shah Zafar Marg
NEW DELHI 110002

Telephone

{ 323 76 17
{ 323 38 41

Eastern : 1/14 C. I. T. Scheme VII M, V. I. P. Road, Kankurgachi
KOLKATA 700054

{ 337 84 99, 337 85 61
{ 337 86 26, 337 91 20

Northern : SCO 335-336, Sector 34-A, CHANDIGARH 160022

{ 60 38 43
{ 60 20 25

Southern : C. I. T. Campus, IV Cross Road, CHENNAI 600113

{ 235 02 16, 235 04 42
{ 235 15 19, 235 23 15

Western : Manakalaya, E9 MIDC, Marol, Andheri (East)
MUMBAI 400093

{ 832 92 95, 832 78 58
{ 832 78 91, 832 78 92

Branches : AHMEDABAD. BANGALORE. BHOPAL. BHUBANESHWAR. COIMBATORE.
FARIDABAD. GHAZIABAD. GUWAHATI. HYDERABAD. JAIPUR. KANPUR.
LUCKNOW. NAGPUR. NALAGARH. PATNA. PUNE. RAJKOT. THIRUVANANTHAPURAM.
VISHAKHAPATNAM.

AMENDMENT NO. 4 OCTOBER 2008
TO
IS 4326 : 1993 EARTHQUAKE RESISTANT DESIGN
AND CONSTRUCTION OF BUILDINGS — CODE OF
PRACTICE

(Second Revision)

(Page 11, Table 4) — Insert the following footnote at the end:

‘NOTE — Four storey building not allowed in Category E’.

(CED 39)

Reprography Unit, BIS, New Delhi, India